

McCue Corporation

Cart**Stop** FlexCore Bollard



Say goodbye to the time-consuming, cumbersome process involved with installing core drilled bollards. With no more holes to dig, concrete to pour or pipes to paint, the FlexCore Bollard can be installed in a fraction of the time and at a much lower cost. But rest assured, this ease of installation comes with no sacrifice in strength, due to FlexCore's innovative energy absorbing core technology. The FlexCore Bollard has undergone extensive testing to qualify it for use for all types of heavy duty applications.

STRONG: Energy absorbing design withstands impacts from pallet jacks, cars, forklifts or trucks, without damage to the concrete.

SPEEDY INSTALL: With only 3 bolts, the FlexCore Bollard can be installed in under 10 minutes; no core drilling.

EASILY RELOCATED: Because the FlexCore Bollard is not embedded in the ground, it can be easily removed or relocated.



Applications

- Drive-thrus
- Loading Dock Doors
- Entrances & Exits
- Walkways
- Parking Lots
- Parking Garages
- Entrance Ways
- ATM Machines
- Generators
- Retail Backrooms
- Warehouses



www.mccue.com

Cart**Stop** FlexCore Bollard

McCue Corporation

Cart**Stop** Flex**Core** Bollard

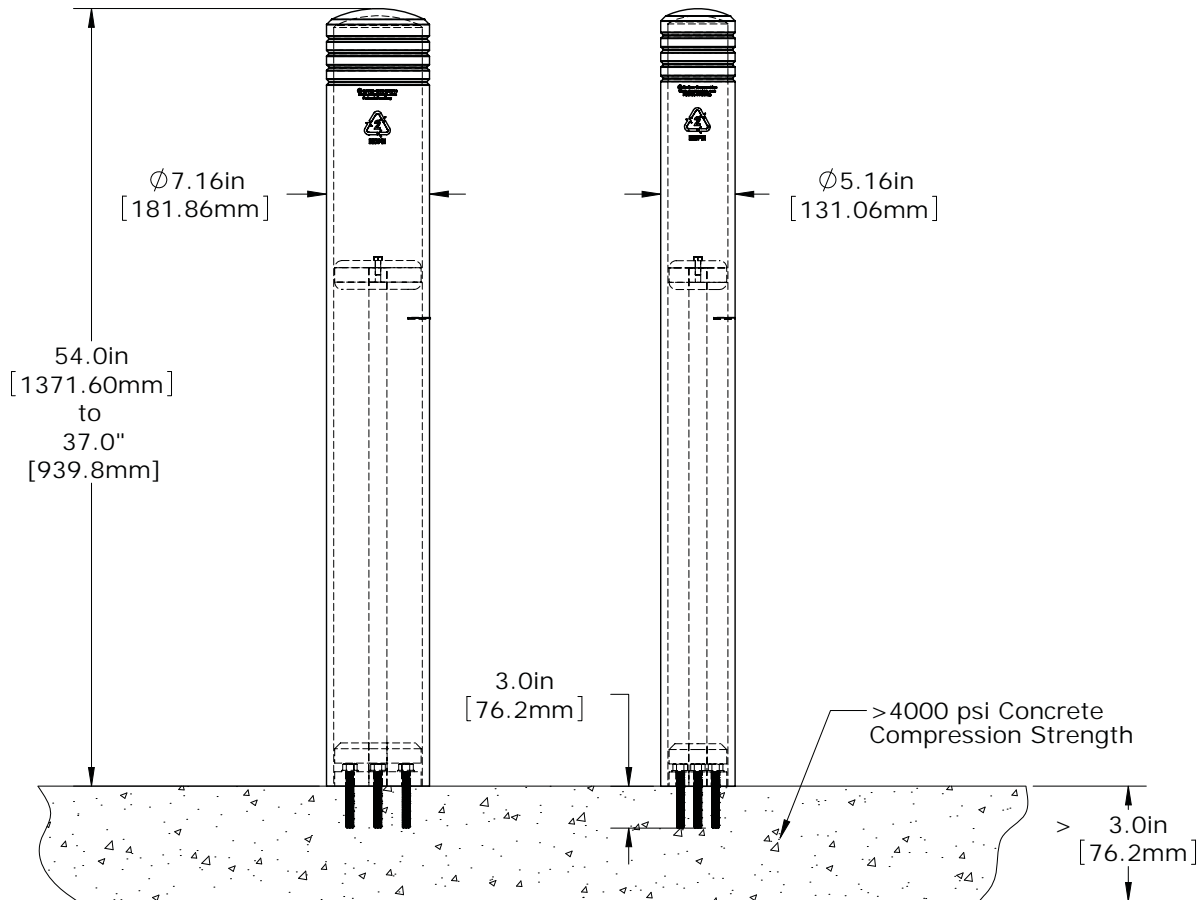

McCue
Corporation

McCue Corporation
35 Congress Street, Suite 150, Salem, MA 01970 USA
Phone: (800) 800-8503 or (978) 741-8500
Fax: (978) 741-2542
Email: cservices@mccue.com

www.mccue.com

©2010 McCue Corporation. Printed in USA
Patent Pending.

Placing an order:

There are five easy ways to order:

- 1) E-mail your order: cservices@mccue.com
- 2) Phone our toll-free number: (800) 800-8503 or call (978) 741-2542
- 3) FAX in your order: (978) 741-2542
- 4) Mail in your purchase order
- 5) Online at www.mccue.com

(Rev. 12/10)