



BUMPERSIGN SOLAR

**SUSTAINABLE
SOLAR POWERED
SIGNAGE**

Automatically illuminates at dusk

THE MCCUE DIFFERENCE

HI, WE'RE MCCUE & WE MAKE SAFETY EASY!

Our design philosophy is simple — we innovate with our customers every day to solve their most pressing problems. BumperSign Solar was engineered with that methodology and is revolutionizing retail sign innovation with these three principals:



BUILT TO LAST

Designed to thrive in retail parking lots, our products resist wear and tear.



EASE OF INSTALL

Simple installation with just four anchors into most parking surfaces.



AESTHETICS

Finally a sign that meets your brand standards.

**A BETTER, SAFER SHOPPING EXPERIENCE BEGINS AND ENDS IN THE PARKING LOT —
SPEAK TO A SIGNAGE EXPERT TODAY (800) 800-8503**

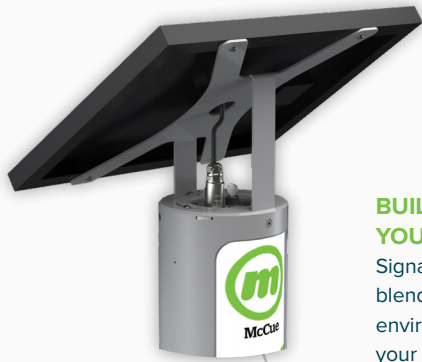

LOW MAINTENANCE:
Solar powered and water-tight, this sign requires no upkeep!

BUILT FOR YOUR BRAND:
Signage blends into the environment so your brand stands out.



EASY-TO-CUSTOMIZE:
Custom illuminated nameplates adhere to light dispersing acrylic.

WITHSTANDS IMPACTS:
Innerspring technology flexes to absorb bumps from vehicles.

FAST INSTALLATION:
Easily installs with 4 anchors into concrete or asphalt – no power required!



See what's inside

BUMPERSIGN SOLAR

Improve the customer experience in your parking lots with an environmentally friendly backlit sign. Powered by the sun, **BumperSign Solar** automatically turns on at dusk, keeping your signage highly visible and bringing order to your lots. Engineered with a strong inner core to deflect and dissipate impacts, this signage solution brightly extends your brand outdoors and will last for years.

THE BENEFITS OF SOLAR

Reusable and Energy Efficient



* PATENTS PENDING

BUMPERSIGN **SOLAR**

BumperSign Solar

KIT NUMBER: BSS-KIT

Hardware included.

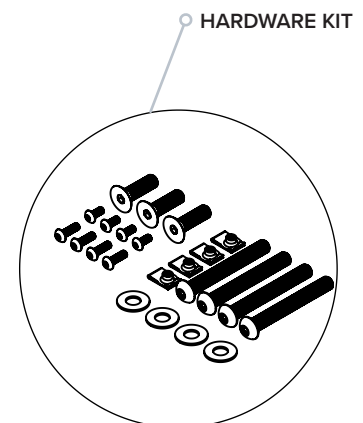
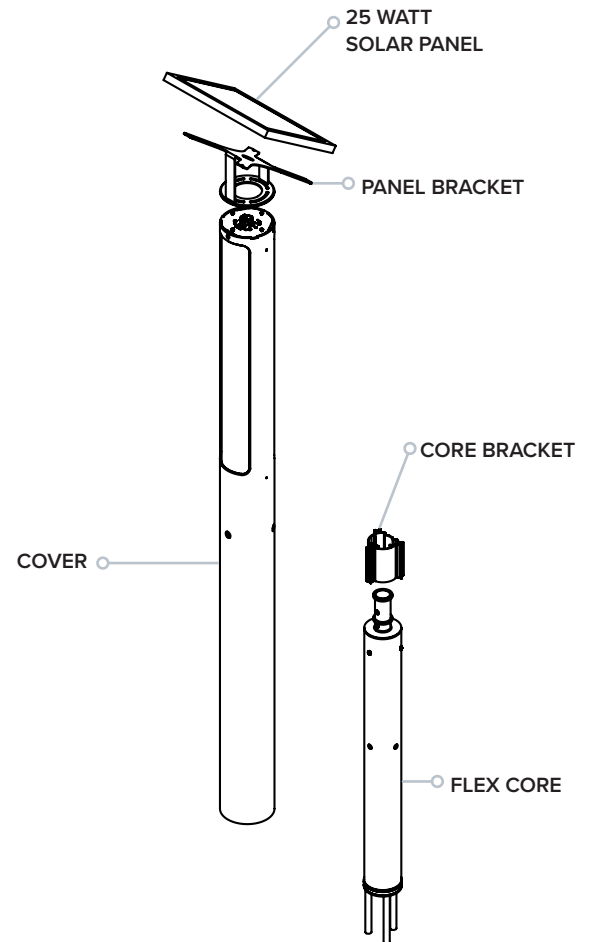
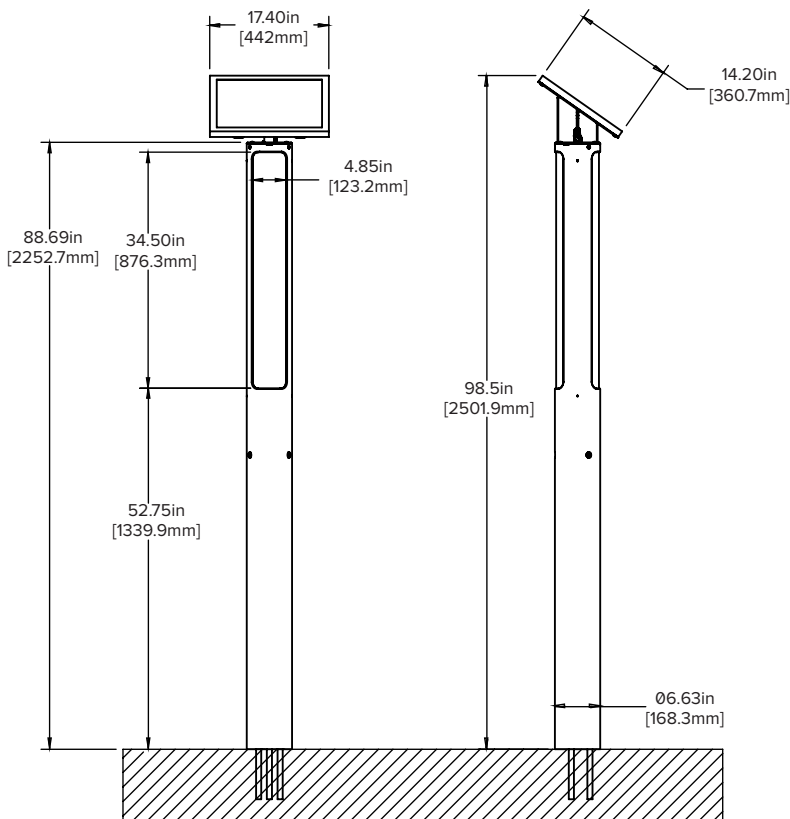

* PATENTS PENDING