

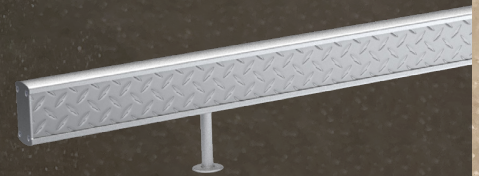

CARTSTOP FLIP DIAMOND PLATE



**FLOOR-MOUNTED RAIL SYSTEM THAT PROTECTS
YOUR ASSETS AND PREVENTS CART DAMAGE**

**KEEP YOUR OPERATIONS SAFE AND YOUR WORKFORCE SAFER WITH THE WORLD'S MOST
ADVANCED SAFETY BARRIERS — SPEAK TO A SAFETY SPECIALIST TODAY**

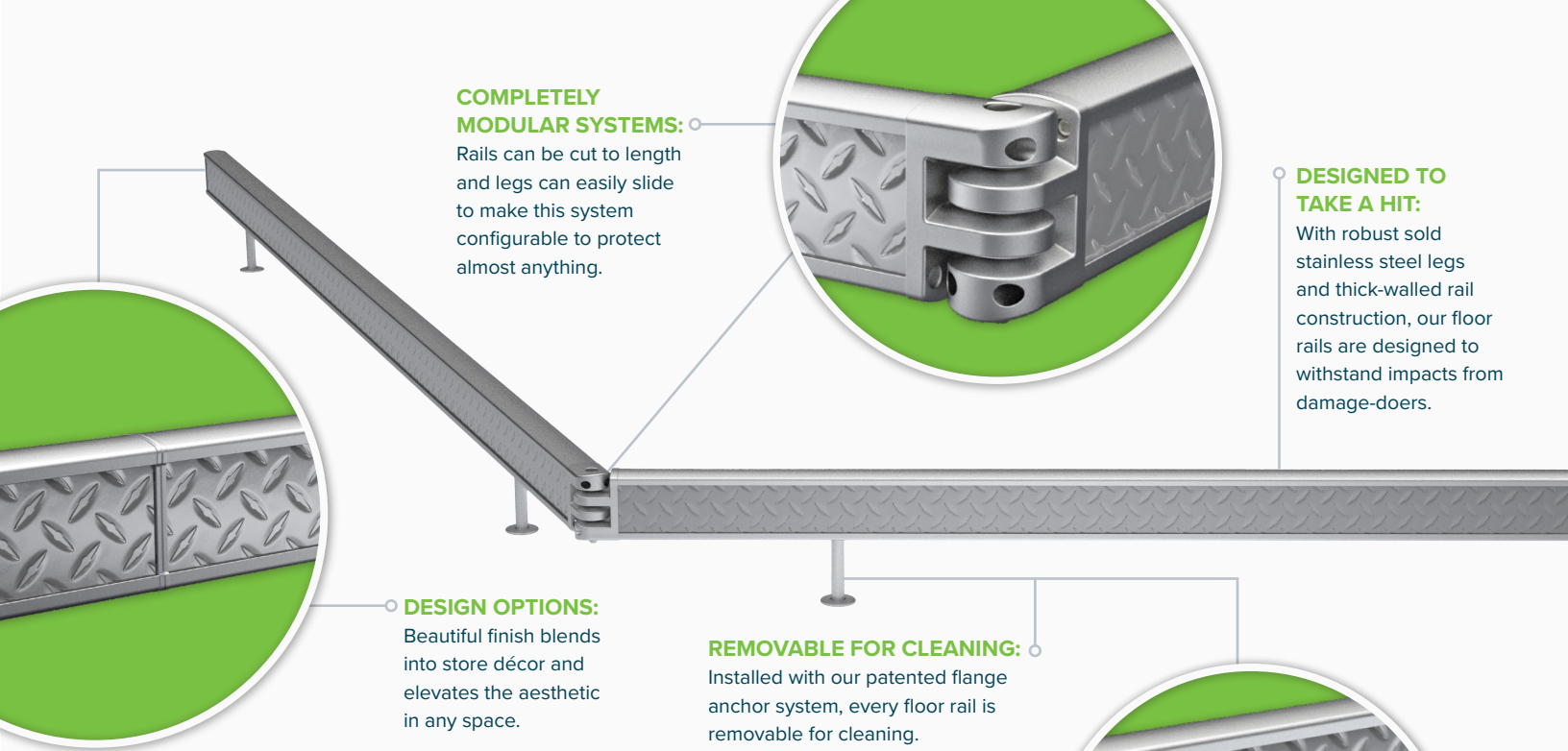

COMPLETELY MODULAR SYSTEMS:
 Rails can be cut to length and legs can easily slide to make this system configurable to protect almost anything.

DESIGNED TO TAKE A HIT:
 With robust solid stainless steel legs and thick-walled rail construction, our floor rails are designed to withstand impacts from damage-doers.

DESIGN OPTIONS:
 Beautiful finish blends into store décor and elevates the aesthetic in any space.

REMOVABLE FOR CLEANING:
 Installed with our patented flange anchor system, every floor rail is removable for cleaning.

CARTSTOP FLIP DIAMOND PLATE

Engineered to deflect runaway carts, **CartStop Flip Diamond Plate** combines sleek aesthetics with powerful strength, keeping your walls, cases and fixtures in pristine condition and looking good. Provide the safety and security your store requires to match the pace your customer's demand.

ELEVATE YOUR SALES FLOOR



* PATENTS PENDING

IMPACT TESTING

Rigorous product testing at the highest standard.

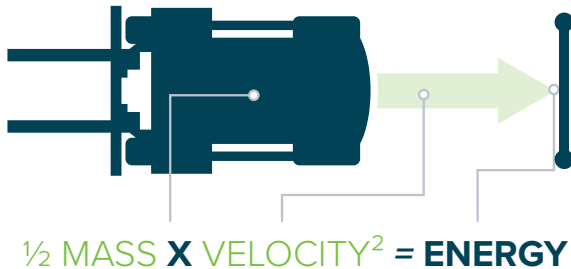

Ultimate Strength Rating
21,954ft-lbs (29,766 J)

 X 

8755 lbs (3971 kg) **8.66 mph (13.94 kmh)**

90°	21,954 ft-lbs	29,766 J
------------	----------------------	-----------------

45°	31,053 ft-lbs	42,102 J
------------	----------------------	-----------------

30°	43,909 ft-lbs	59,532 J
------------	----------------------	-----------------

WHAT DOES 21,954 FT LBS (29,766 J) MEAN TO YOU?

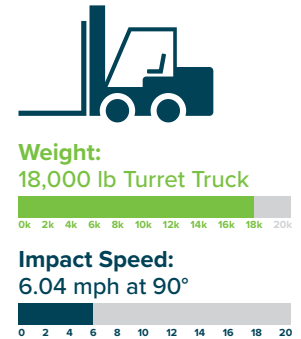
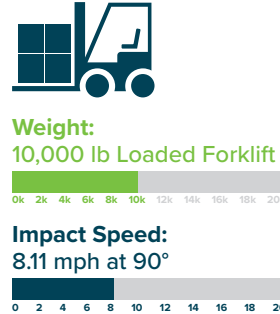
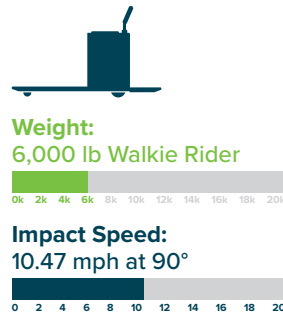
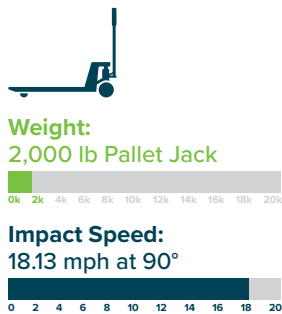

MATERIAL PROPERTIES

BARRIER DEFLECTION: Limited deflection and maximum energy absorption.

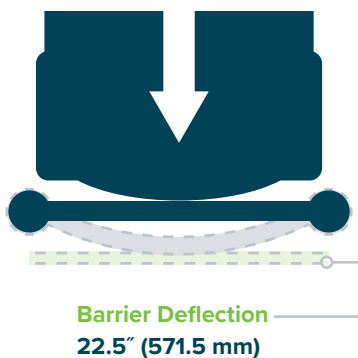

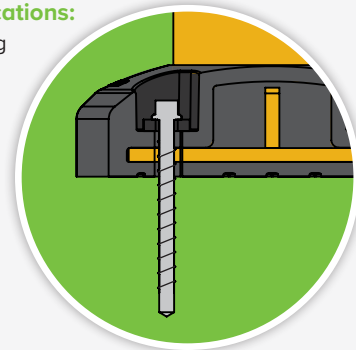

Anchor Specifications:

A shock-absorbing anchor system protects both the anchors and the floor.



	Working Temperatures	32°F-130°F (0°C-54°C)
	Toxicity	Not Hazardous

	Flammability	Does Not Easily Ignite
	REACH / RSCA / DSL	Compliant

* PATENTS PENDING

CARTSTOP FLIP *DIAMOND PLATE*

CartStop Flip Diamond Plate

Part #: CSFL-C-96-910

Hardware included.
Lead time: 12 weeks.

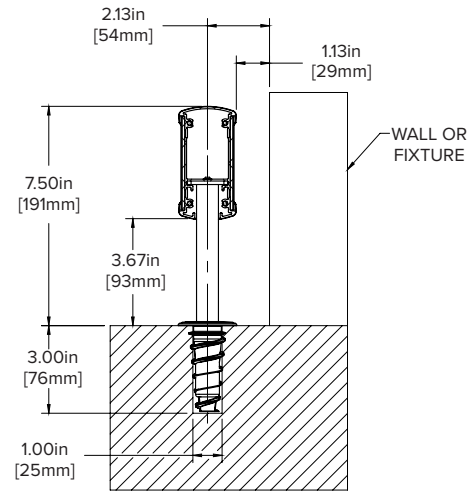
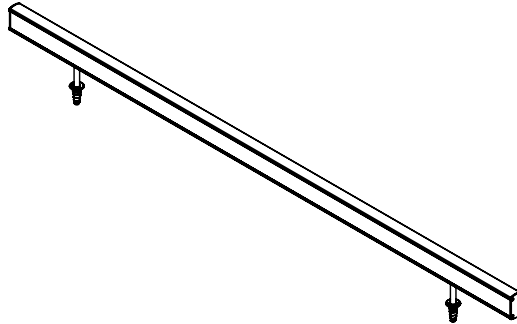

MOUNTING DETAIL

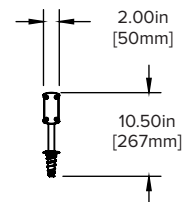
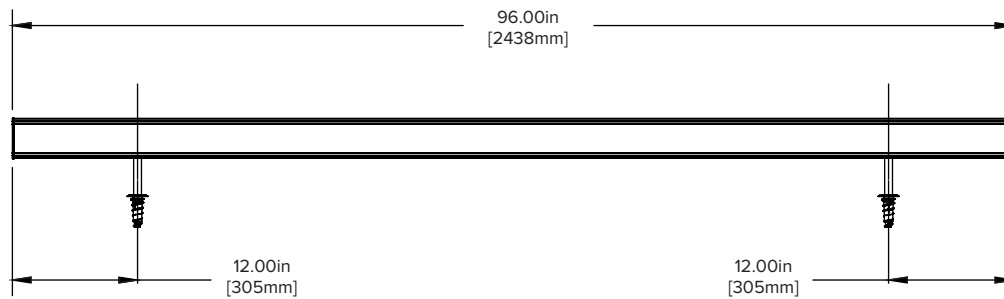

CartStop Flip Diamond Plate Adjustable Corner

Part #: CSFL-C-4x4-910

Hardware included.
Lead time: 12 weeks.

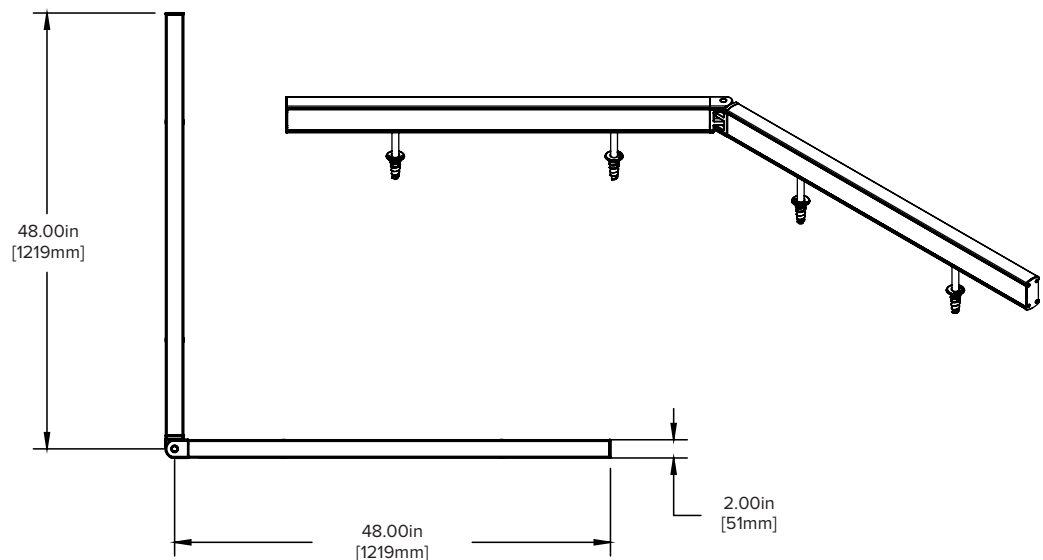

* PATENTS PENDING