



mccue.com   
cservices@mccue.com   
(800) 800-8503 



# SAFESTOP FORKLIFT GATE



**ELEVATE WAREHOUSE SAFETY WITH FORKLIFT  
TRAFFIC CONTROL**

**KEEP YOUR OPERATIONS SAFE AND YOUR WORKFORCE SAFER WITH THE WORLD'S MOST  
ADVANCED SAFETY BARRIERS — SPEAK TO A SAFETY SPECIALIST TODAY (800) 800-8503**

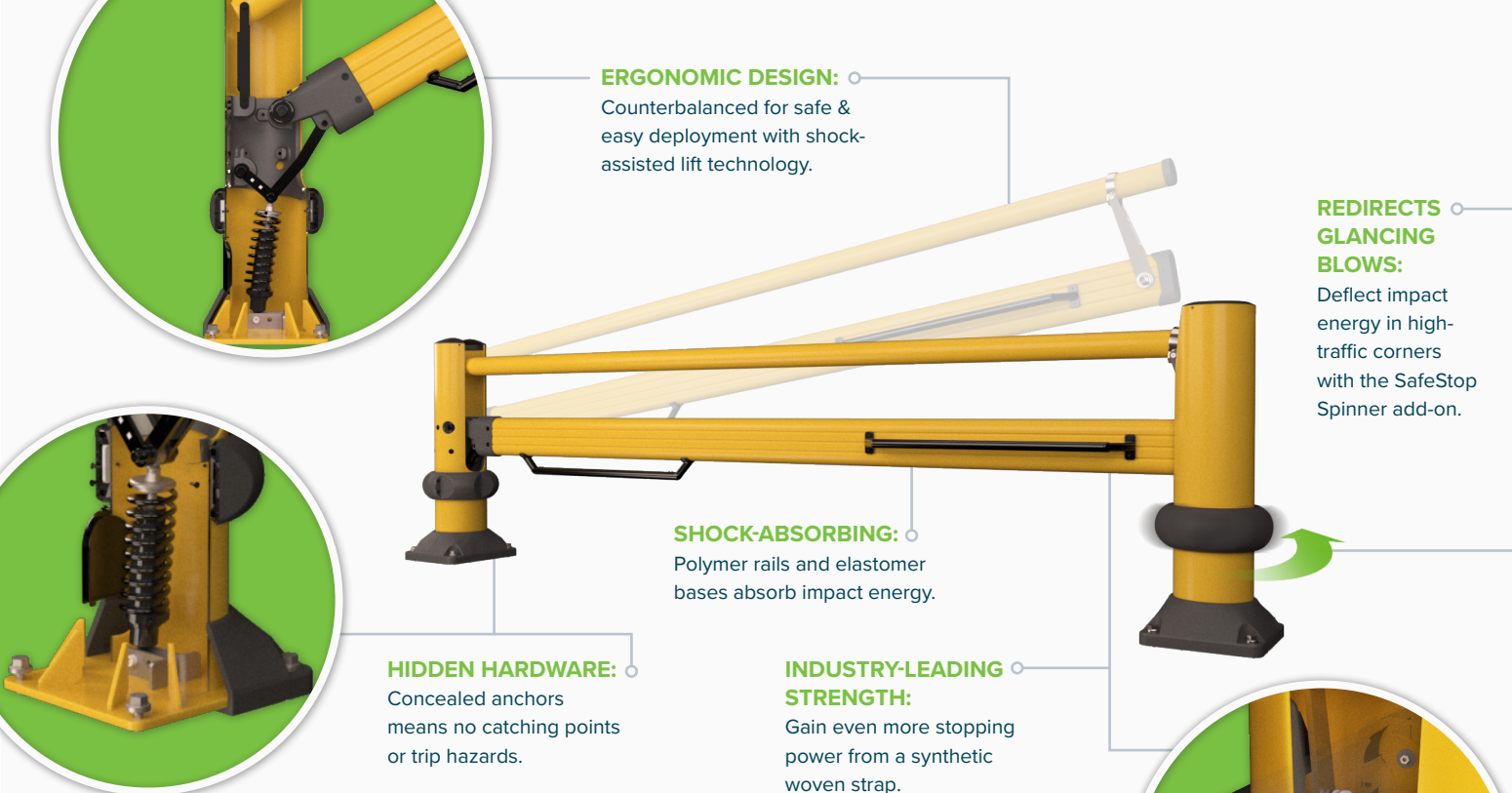

**ERGONOMIC DESIGN:**  
Counterbalanced for safe & easy deployment with shock-assisted lift technology.

**REDIRECTS GLANCING BLOWS:**  
Deflect impact energy in high-traffic corners with the SafeStop Spinner add-on.

**SHOCK-ABSORBING:**  
Polymer rails and elastomer bases absorb impact energy.

**HIDDEN HARDWARE:**  
Concealed anchors means no catching points or trip hazards.

**INDUSTRY-LEADING STRENGTH:**  
Gain even more stopping power from a synthetic woven strap.

# SAFESTOP FORKLIFT GATE

Meet **SafeStop ForkLift Gate**, a strong floor-mounted gate system that allows for temporary access within your facility, safely separating people and forklifts. This ergonomic, easy-to-deploy system utilizes a shock-assisted rail system so operators can open and close access to aisles and doorways with ease — keeping your people and facility safe.

## HOW IT WORKS

Engineered for ease of use with a spring-assisted design that ensures ergonomic opening and closing.



\* PATENTS PENDING

## IMPACT TESTING

Rigorous product testing at the highest standard.

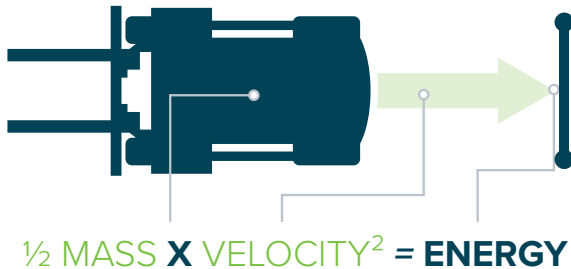

**Ultimate Strength Rating**  
**11,571 ft-lbs (15,689 J)**

 **x** 

**8710 lbs (3951 kg)**      **6.30 mph (10.15 kmh)**

<b>90°</b>	<b>11,571 ft-lbs</b>	<b>15,689 J</b>
------------	----------------------	-----------------

<b>45°</b>	<b>16,367 ft-lbs</b>	<b>22,190 J</b>
------------	----------------------	-----------------

<b>30°</b>	<b>23,143 ft-lbs</b>	<b>31,377 J</b>
------------	----------------------	-----------------

### WHAT DOES 11,571 FT LBS (15,689 J) MEAN TO YOU?

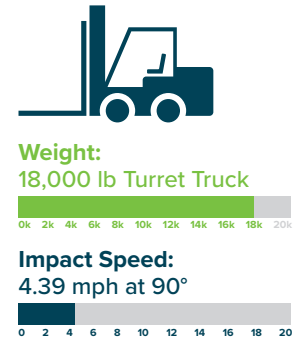
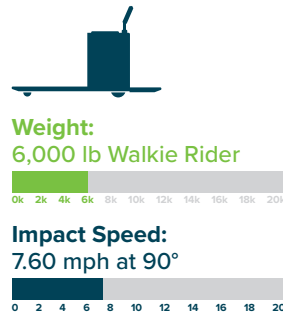
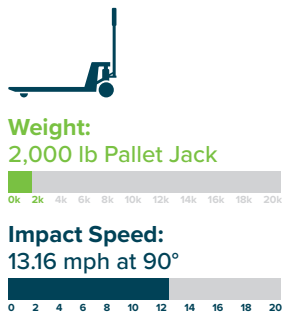

## MATERIAL PROPERTIES

**BARRIER DEFLECTION:** Limited deflection and maximum energy absorption.

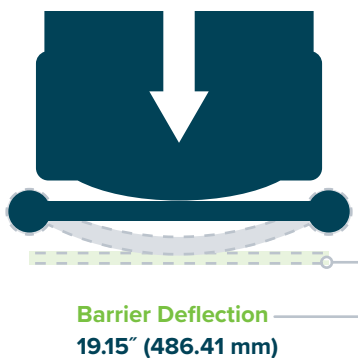

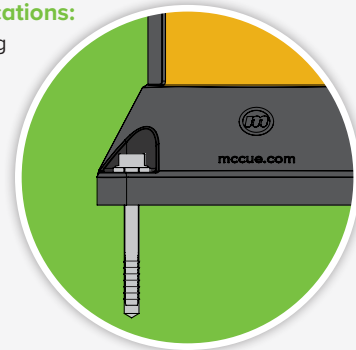

### Anchor Specifications:

A shock-absorbing anchor system protects both the anchors and the floor.



	<b>Working Temperatures</b>	<b>32°F-130°F (0°C-54°C)</b>
	<b>Toxicity</b>	<b>Not Hazardous</b>

	<b>Flammability</b>	<b>Does Not Easily Ignite</b>
	<b>REACH / RSCA / DSL</b>	<b>Compliant</b>

\* PATENTS PENDING

# SAFESTOP FORKLIFT GATE

## SafeStop ForkLift Gate 96"

**Part #: SFG-K-096-307**

Hardware included.  
 Lead time: 14 weeks.

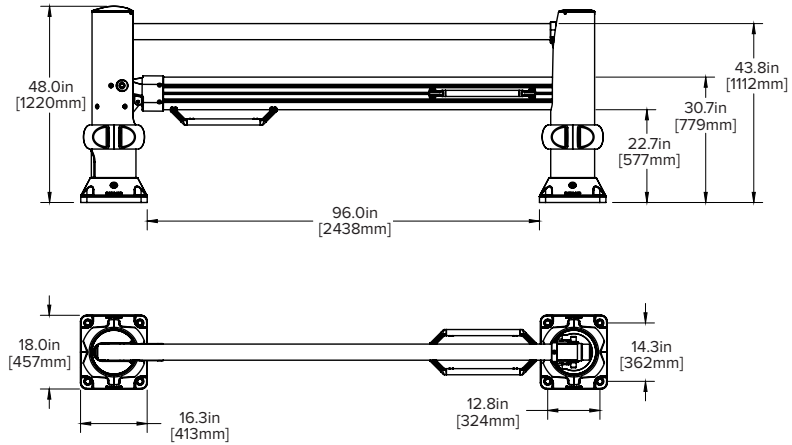
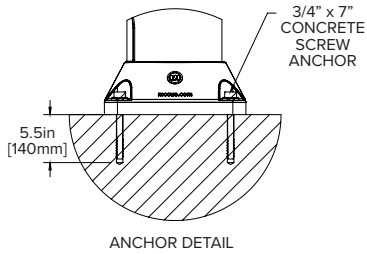

## SafeStop ForkLift Gate 120"

**Part #: SFG-K-120-307**

Hardware included.  
 Lead time: 14 weeks.

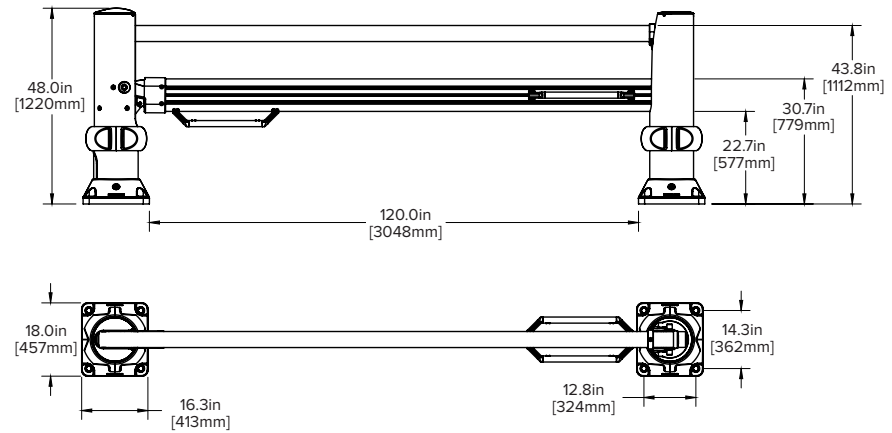
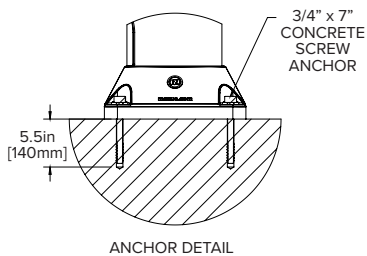

## SafeStop ForkLift Gate 144"

**Part #: SFG-K-144-307**

Hardware included.  
 Lead time: 14 weeks.

