



SAFESTOP GUARDRAIL

**INNOVATIVE GUARDRAILS
KEEP YOUR PEOPLE SAFE**



*Strong uprights and flexible rails
provide ultimate stopping power*

THE MCCUE DIFFERENCE

HI, WE'RE MCCUE & WE MAKE SAFETY EASY!

Our innovative, impact-tested barriers safely stop fast-moving material handling vehicles — protecting your people and your facility. With engineered materials that work together, we're revolutionizing safety barrier innovation with these three principles:



SAFER IMPACTS

Strong, floor-mounted rail designed to bring heavy trucks to a stop.



SHOCK ABSORPTION

Absorbs impacts — with limited deflection — to keep your people safe.



EASY INSTALL

Simple install with standard hardware and tools.



McCue

EASY-TO-CONFIGURE:
Modular posts and rails allow for endless configurations.



SAFER IMPACTS:
Proprietary rail connection provides unparalleled impact absorbency.



STOPPING POWER:
Industry-leading upright strength from shock-absorbing post technology.

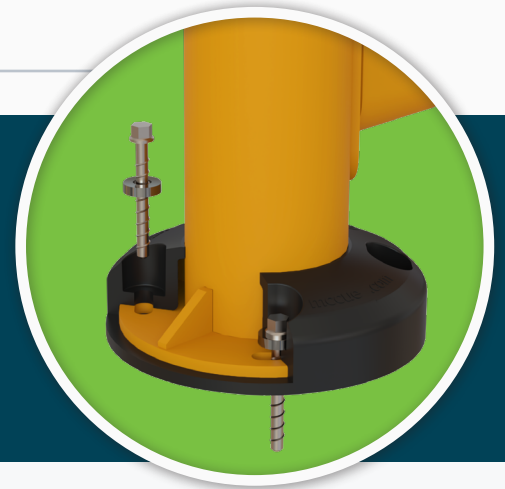

SAFESTOP GUARDRAIL

Meet **SafeStop GuardRail**, a strong plate-mounted barrier that safely stops moving material handling vehicles. Engineered to safely absorb impacts —with flexible polymer rails — to protect your people, workspace, and bottom line.

HOW IT WORKS

GuardRail is packed full of innovative technology to safely stop heavy machinery. Upon impact, its reinforced uprights offer strength while its shock-absorbing rails flex to dissipate impact energy — keeping your operators, forklifts, and facility safe.



* PATENTS PENDING

IMPACT TESTING

Rigorous product testing at the highest standard.

Ultimate Strength Rating



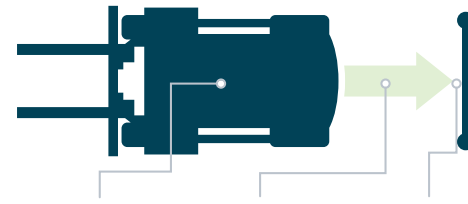

 <p>SafeStop GuardRail 16,226 ft-lbs (22,000 J)</p>	 <p>SafeStop GuardRail with FloorGuard 21,389 ft-lbs (29,000 J)</p>
---	---



$\frac{1}{2} \text{ MASS X VELOCITY}^2 = \text{ENERGY}$

90°	21,389 ft-lbs	29,000 J	45°	42,764 ft-lbs	57,988 J	30°	85,529 ft-lbs	115,977 J
------------	----------------------	-----------------	------------	----------------------	-----------------	------------	----------------------	------------------

WHAT DOES 21,389 FT LBS (29,000 J) MEAN TO YOU?

 <p>Weight: 2,000 lb Pallet Jack</p> <p>0k 2k 4k 6k 8k 10k 12k 14k 16k 18k 20k</p> <p>Impact Speed: 17.9 mph at 90°</p> <p>0 2 4 6 8 10 12 14 16 18</p>	 <p>Weight: 6,000 lb Walkie Rider</p> <p>0k 2k 4k 6k 8k 10k 12k 14k 16k 18k 20k</p> <p>Impact Speed: 10.3 mph at 90°</p> <p>0 2 4 6 8 10 12 14 16 18</p>	 <p>Weight: 10,000 lb Loaded Forklift</p> <p>0k 2k 4k 6k 8k 10k 12k 14k 16k 18k 20k</p> <p>Impact Speed: 8.0 mph at 90°</p> <p>0 2 4 6 8 10 12 14 16 18</p>	 <p>Weight: 18,000 lb Turret Truck</p> <p>0k 2k 4k 6k 8k 10k 12k 14k 16k 18k 20k</p> <p>Impact Speed: 6.0 mph at 90°</p> <p>0 2 4 6 8 10 12 14 16 18</p>
--	---	--	---

MATERIAL PROPERTIES

BARRIER DEFLECTION:

Flexible rails for maximum energy absorption.

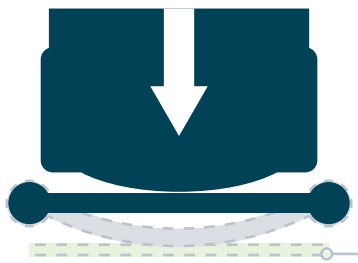

Barrier Deflection
22.5" (571.5 mm)

Anchor Specifications:

A shock-absorbing anchor system protects both the anchors and the floor.

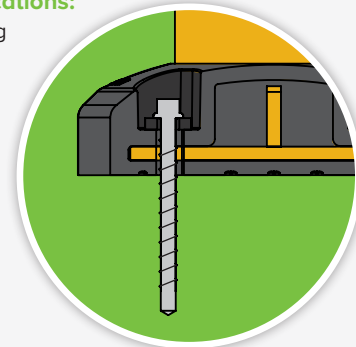

	Working Temperatures	32°F-130°F (0°C-54°C)
	Toxicity	Not Hazardous

	Flammability	Does Not Easily Ignite
	REACH / TSCA / DSL	Compliant

* PATENTS PENDING

SAFESTOP *GUARDRAIL*

SafeStop GuardRail

Hardware included.

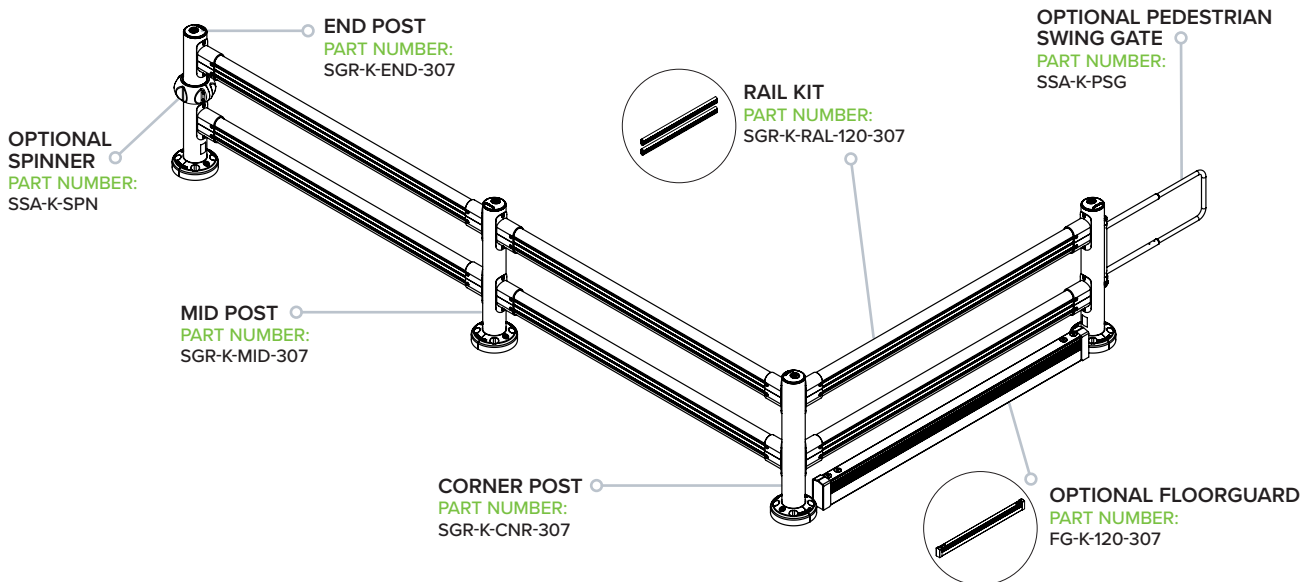
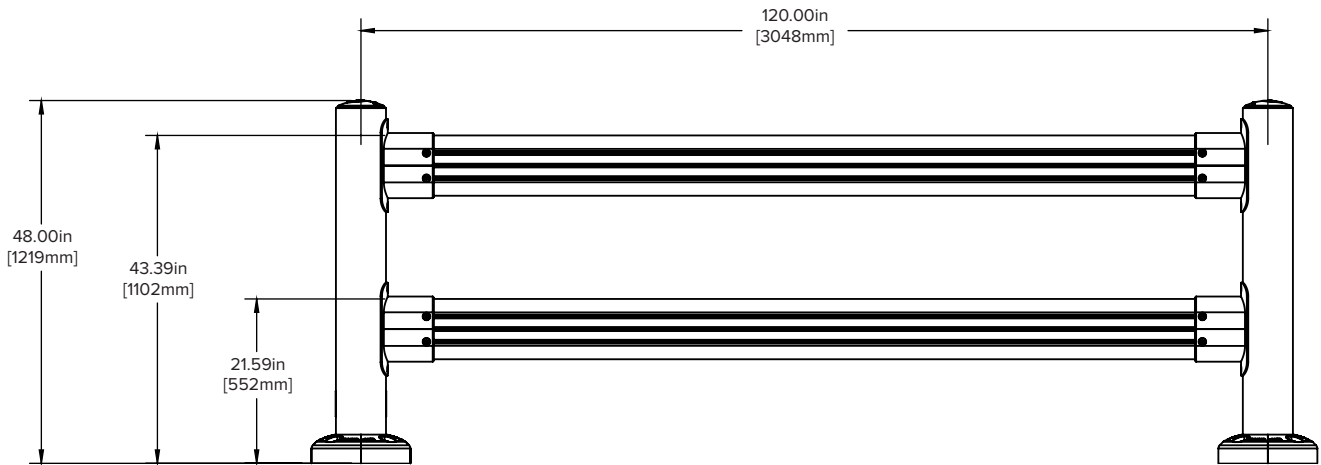
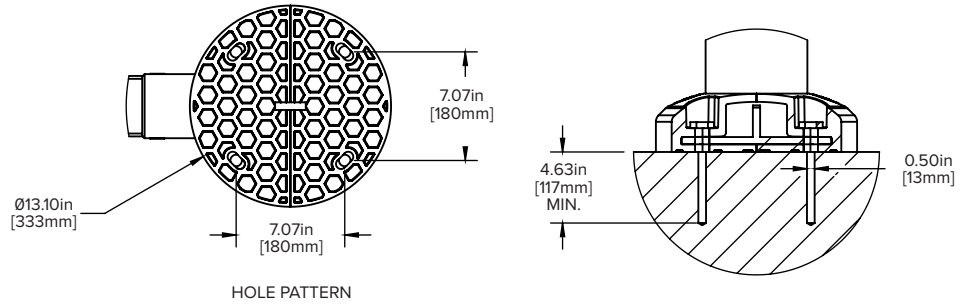

* PATENTS PENDING