

Bollard CartMagnet Standard Open Unit

INSTALLATION INSTRUCTIONS

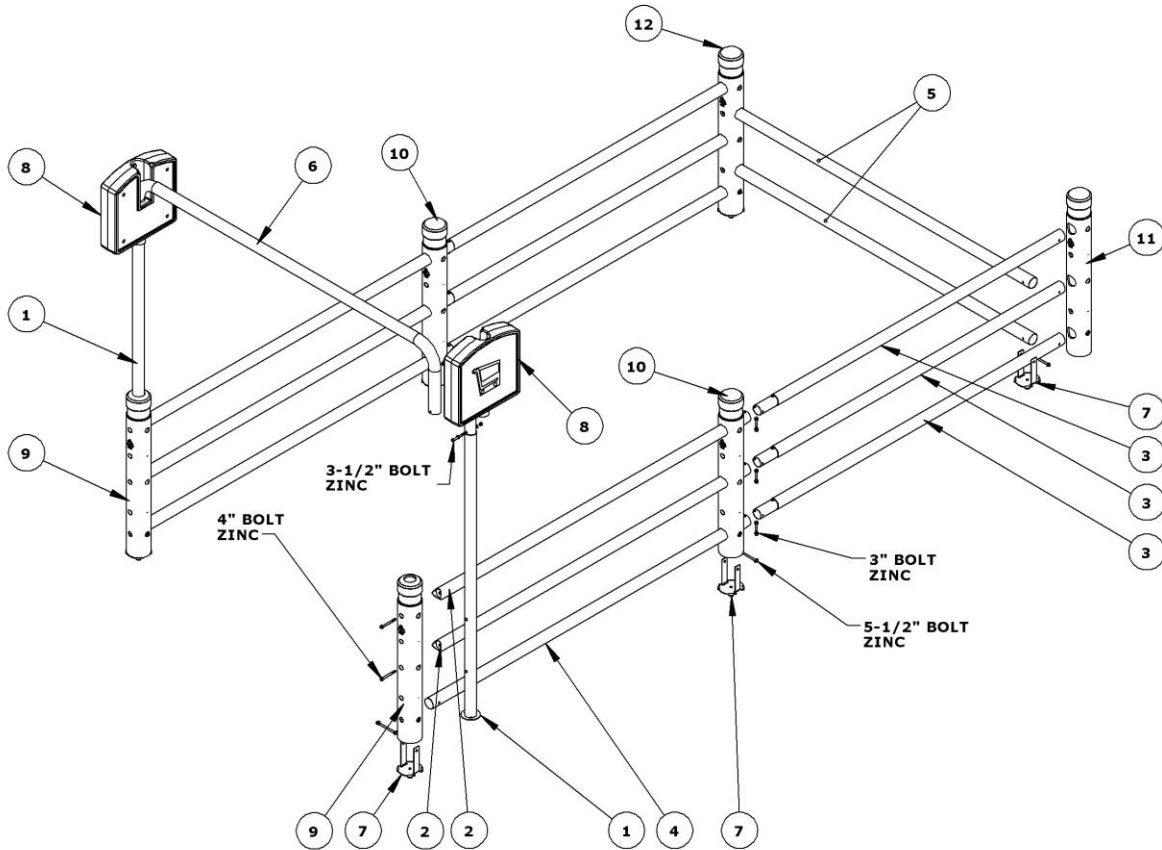

BCM-3S-401 BOLLARD CARTMAGNET 3 WIDE STANDARD BLACK (2018)			McCUE DWG'S	REV
ITEM #	QTY	DESCRIPTION		
1	2	2.5" OD TUBING, 76-7/16" LONG, FRONT UPRIGHT	BCMC-FRONT-UPRIGHT	A
2	4	2.5" OD TUBING, 91" LONG, FISH MOUTH FRONT RAIL WELDED-ASM WITH INTERNAL THREADED NUT	BCMC-FRONT-RAIL-ASM	A
3	6	2.5" OD TUBING, 88-11/16" LONG, REAR RAIL SWAGED	BCMC-REAR-RAIL	A
4	2	2.5" OD TUBING, 92-11/16" LONG, BOTTOM FRONT RAIL	BCMC-FRONT-BOTT-RAIL	A
5	2	2.5" OD TUBING, 89-13/16" LONG, STOPBAR 3W 86-1/2" C-C	BCMC-STOPBAR3	A
6	1	2.5" OD TUBING, 89" X 17" TALL , FRONT CROSSBAR 3W 86-1/2" C-C	BCMC-FRONT-CBAR3	B
7	6	STEEL CLEAT, 6.5" TALL X 5.20" OD, ZINC PLATED	BCMSC-CLEAT	A
8	2	(BM) PLASTIC SIGN 18"L X 18"H X 4.5" WIDE, HDPE	BCMC-SIGN-BM-401	A
9	2	(BM) FRONT BOLLARD	BCMC-FRONT-SHELL-BM-401	B
10	2	(BM) MIDDLE BOLLARD	BCMC-MID-SHELL-BM-401	B
11	1	(BM) BACK RIGHT BOLLARD	BCMC-BR-SHELL-BM-401	B
12	1	(BM) BACK LEFT BOLLARD	BCMC-BL-SHELL-BM-401	B
HARDWARE				
	16	3/8-16 X 4" LONG HEX HEAD BOLT, ZINC	BCMC-HARDWARE	
	6	3/8-16 X 5-1/2" LONG HEX HEAD BOLT, ZINC		
	6	3/8-16 X 3" LONG HEX HEAD BOLT, ZINC		
	2	3/8-16 X 3-1/2" LONG HEX HEAD BOLT, ZINC		
	26	3/8-16 NYLON INSERT HEX FLANGE LOCK NUTS, ZINC 7/16 H		
	56	3/8 FLAT WASHER, (ID 0.40, OD 3/4" X THICKNESS OF 1/16"), ZINC		
REV 11/03/2017				

Questions? Call McCue Customer Care at 800.800.8503

mccue.com

The following installation instructions are provided for guidance only. The seller assumes no liability regarding the improper installation or misapplication of its products. It is the installer's responsibility to check for proper installation and if in doubt, contact your Customer Care representative for assistance. ©2014 McCue Corporation, 13 Centennial Drive Peabody, MA 01960, USA.



BCM3 COMPONENT CHECKLIST

QT Y <input checked="" type="checkbox"/>	PART NO.	FIG
2 <input type="checkbox"/>	BCMC-FRONT-SHELL-BM-401	
2 <input type="checkbox"/>	BCMC-MID-SHELL-BM-401	

QT Y <input checked="" type="checkbox"/>	PART NO.	FIG
1 <input type="checkbox"/>	BCMC-BL-SHELL-BM-401	
1 <input type="checkbox"/>	BCMC-BR-SHELL-BM-401	

QT Y <input checked="" type="checkbox"/>	PART NO.	FIG
2 <input type="checkbox"/>	BCMC-SIGN-BM-401	

QT Y <input checked="" type="checkbox"/>	PART NO.	
6 <input type="checkbox"/>	BCMC-CLEAT	
4 <input type="checkbox"/>	BCMC-FRONT-RAIL-ASM	
2 <input type="checkbox"/>	BCMC-FRONT-UPRIGHT	
2 <input type="checkbox"/>	BCMC-STOPBAR	
6 <input type="checkbox"/>	BCMC-REAR-RAIL	
2 <input type="checkbox"/>	BCMC-FRONT-BOTT-RAIL	
1 <input type="checkbox"/>	BCMC-FRONT-CBAR3	

Bollard CartMagnet Standard Open Unit



1 Layout of Components

Remove all parts from packaging and layout out components in the parking space as shown. The total number of components should match to the Bill Of Materials. If any components are missing do not attempt to install unit.

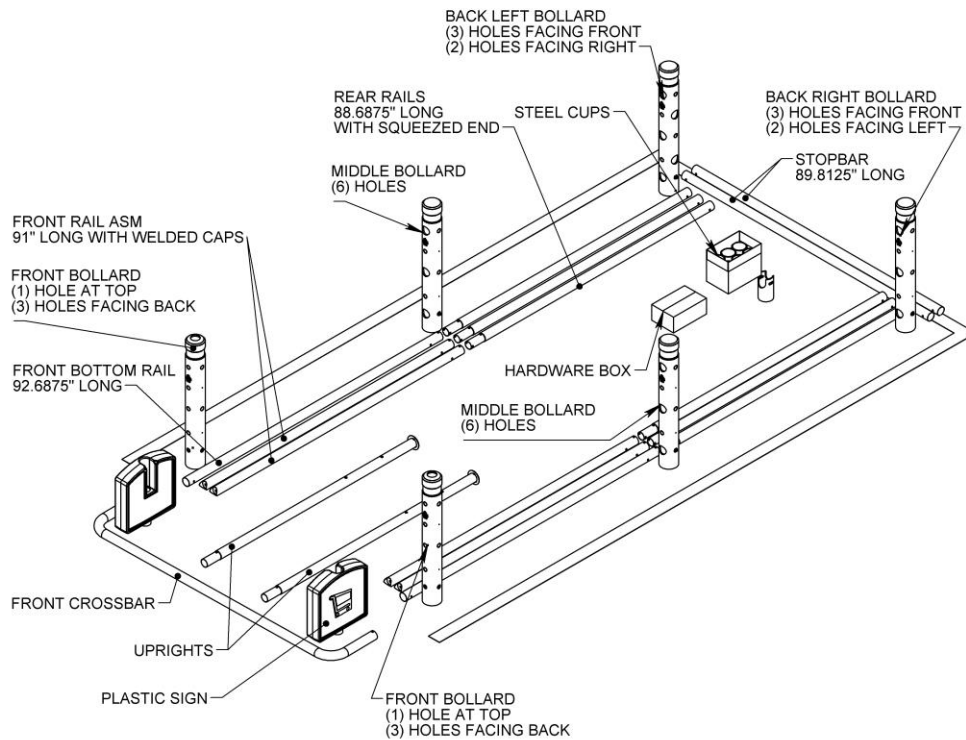

5-1/2" BOLT ASSEMBLY	
$\frac{3}{8}$ "-16 X 5-1/2" HEX HEAD BOLT	 $\frac{3}{8}$ "-16 NYLON LOCK NUT $\frac{3}{4}$ " OD X $\frac{3}{8}$ " ID FLAT WASHER
4" BOLT ASSEMBLY	
$\frac{3}{8}$ "-16 X 4" HEX HEAD BOLT	 $\frac{3}{8}$ "-16 NYLON LOCK NUT $\frac{3}{4}$ " OD X $\frac{3}{8}$ " ID FLAT WASHER
3-1/2" BOLT ASSEMBLY	
$\frac{3}{8}$ "-16 X 3-1/2" HEX HEAD BOLT	 $\frac{3}{8}$ "-16 NYLON LOCK NUT $\frac{3}{4}$ " OD X $\frac{3}{8}$ " ID FLAT WASHER
3" BOLT ASSEMBLY	
$\frac{3}{8}$ "-16 X 3" HEX HEAD BOLT	 $\frac{3}{8}$ "-16 NYLON LOCK NUT $\frac{3}{4}$ " OD X $\frac{3}{8}$ " ID FLAT WASHER

Tools Required:

- Cordless Impact Driver with 9/16 Socket
- Gloves
- 9/16" Wrench Socket
- 3/8" Diameter Drill Bit
- 25' Tape Measure
- Rubber Mallet



2 Assemble Rails into Middle Plastic Bollard

Slide (2) Front Rail Asm and (1) Front Bottom rail into the thru holes of the middle bollard. Holes located 4-1/2" away from the ends of the rails should be aligned with plastic bollard holes. Slide the squeezed ends of the (3) rear rails into the open end of the front rails until bottoms out. Align all holes as shown in detail below.

Rail to Rail: Secure each horizontal railing (front rail connected with rear rail) outside of the plastic bollard using (1) 3" Bolt Assembly.

Rail to Plastic Bollard: Secure rails to plastic bollard by aligning the holes and securing each hole on the plastic bollards with (1) 4" Bolt Assembly, for the top two. Secure bottom rail to plastic bollard with (1) 5-1/2" Bolt Assembly, tightening only by hand.

NOTE: At this stage, 5-1/2" bolts should be tightened only by hand. All 5-1/2" bolts will be removed and re-tightened in step 16 to ensure all components are fully fixed. All 3" and 4" bolt assemblies should be fully tightened.

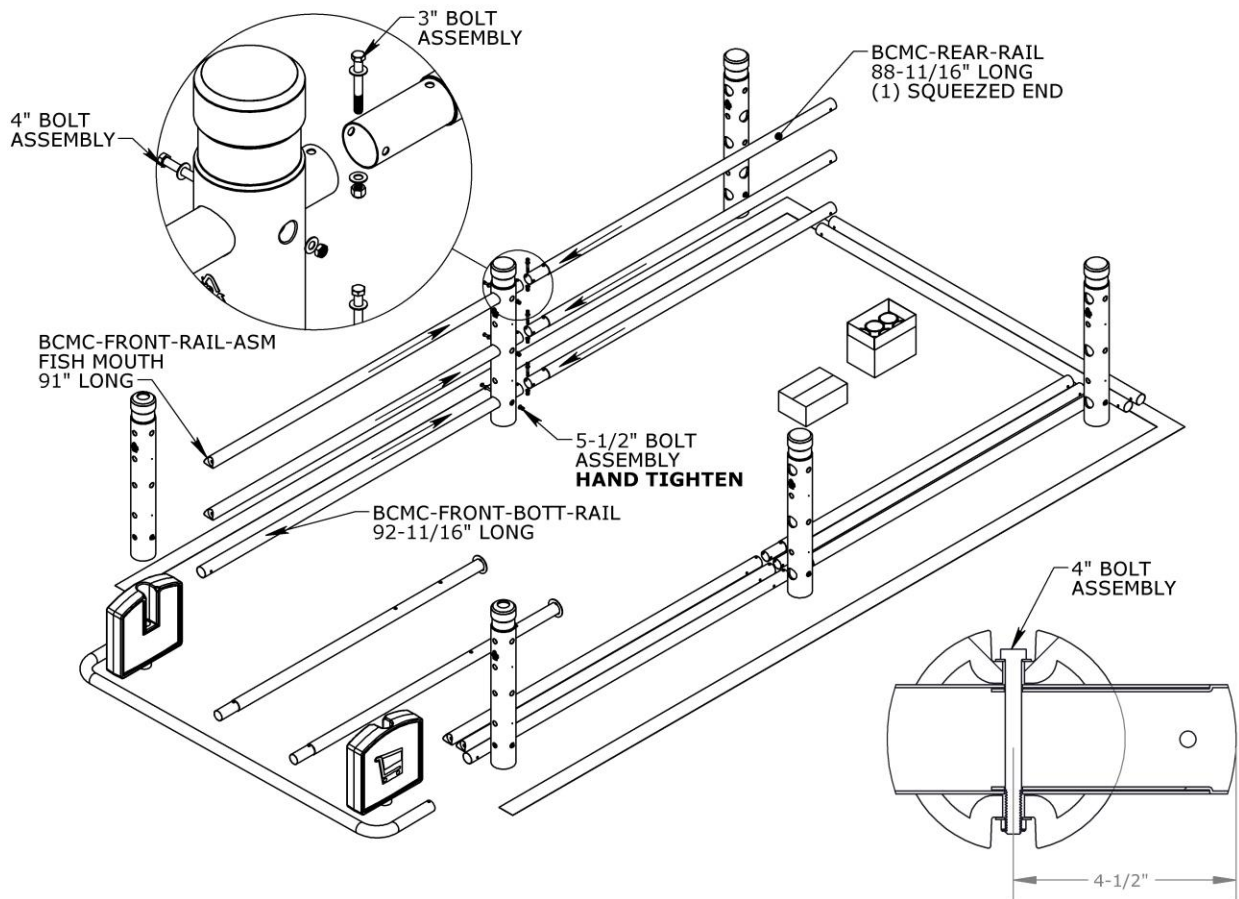



- 3 **Slide Front Upright into Front plastic bollards.**
Slide Upright up into the Front plastic Bollard so that the bottom welded foot plate is raised 7" inside the part.

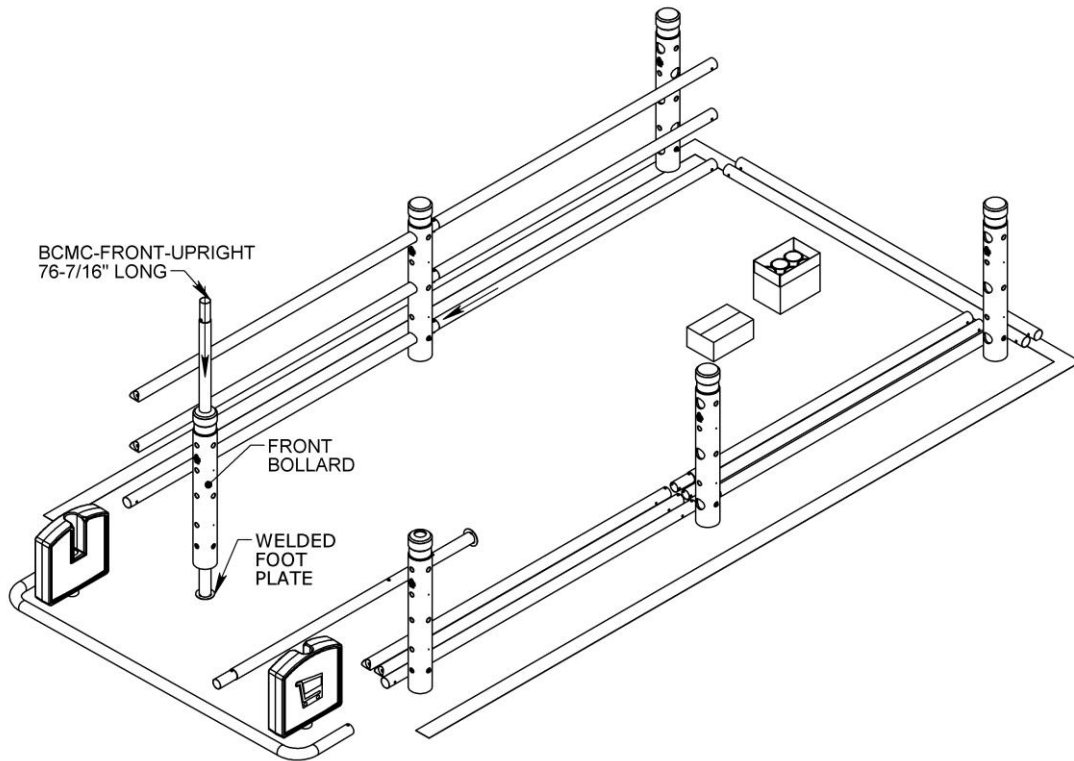



- 4 **Secure front bollard to front rails**
Slide front bollard with upright onto the three open ends of the front rails. Ensure that the bottom welded plate on the upright is raised above the height of the bottom rail. Secure front bollard to each of the two upper Front Rail Asm using (1) 4" Hex bolt and (1) 3/8" ID x 3/4" OD flat washer per rail. Secure the front bottom rail to the bottom of the front plastic bollard with (1) 5-1/2" Bolt Assembly. Hand tighten only.

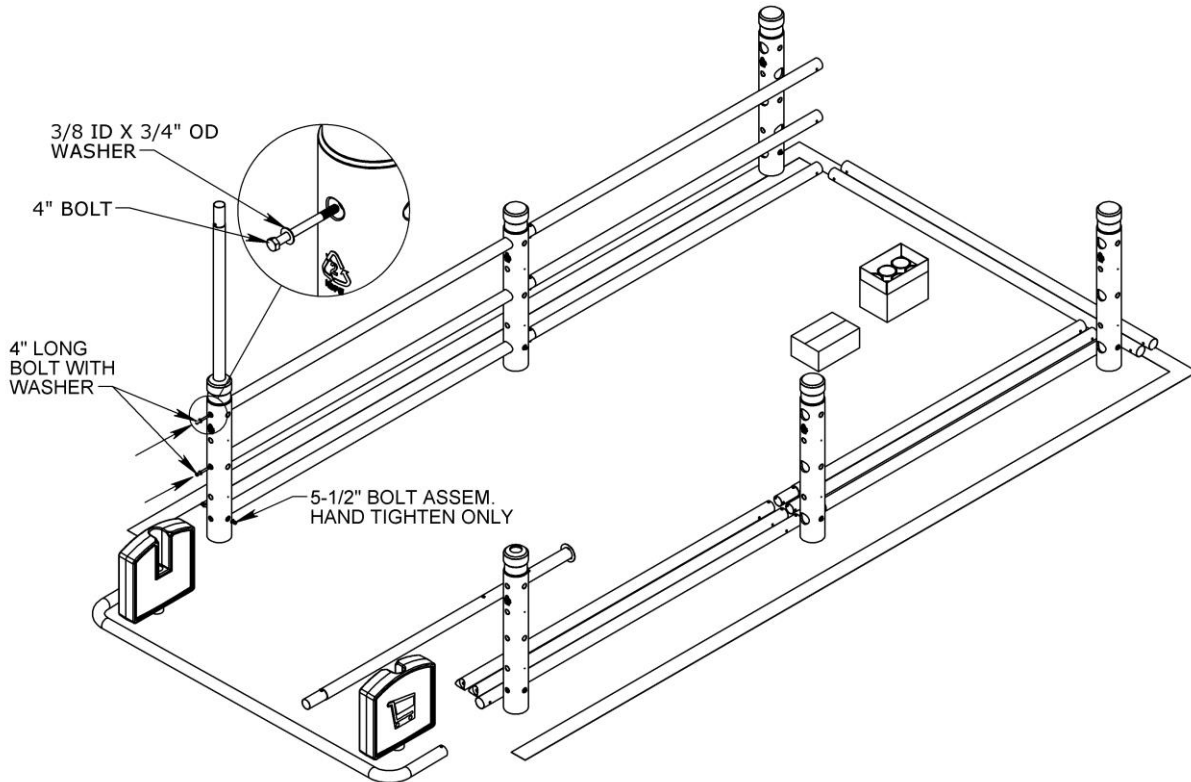



- 5 Secure back left bollard to rear rails**
Slide back left plastic bollard onto the three open ends of the rear rails. Secure back left bollard to each of the two upper rear rails with (1) 4" Bolt Assembly and the bottom rail to back left bollard with (1) 5-1/2" Bolt Assembly.

Note: 5-1/2" bolt assembly is hand tightened only.

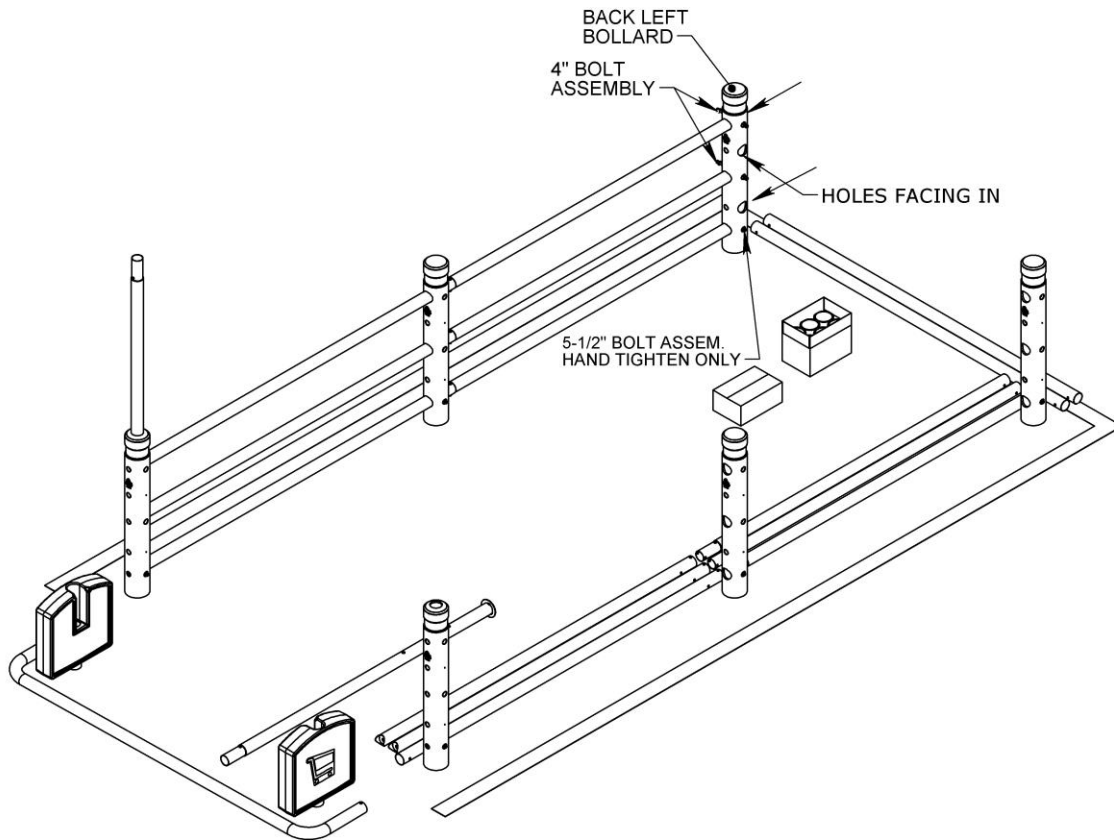



6 | Repeat step 1 through 5 for opposite side.

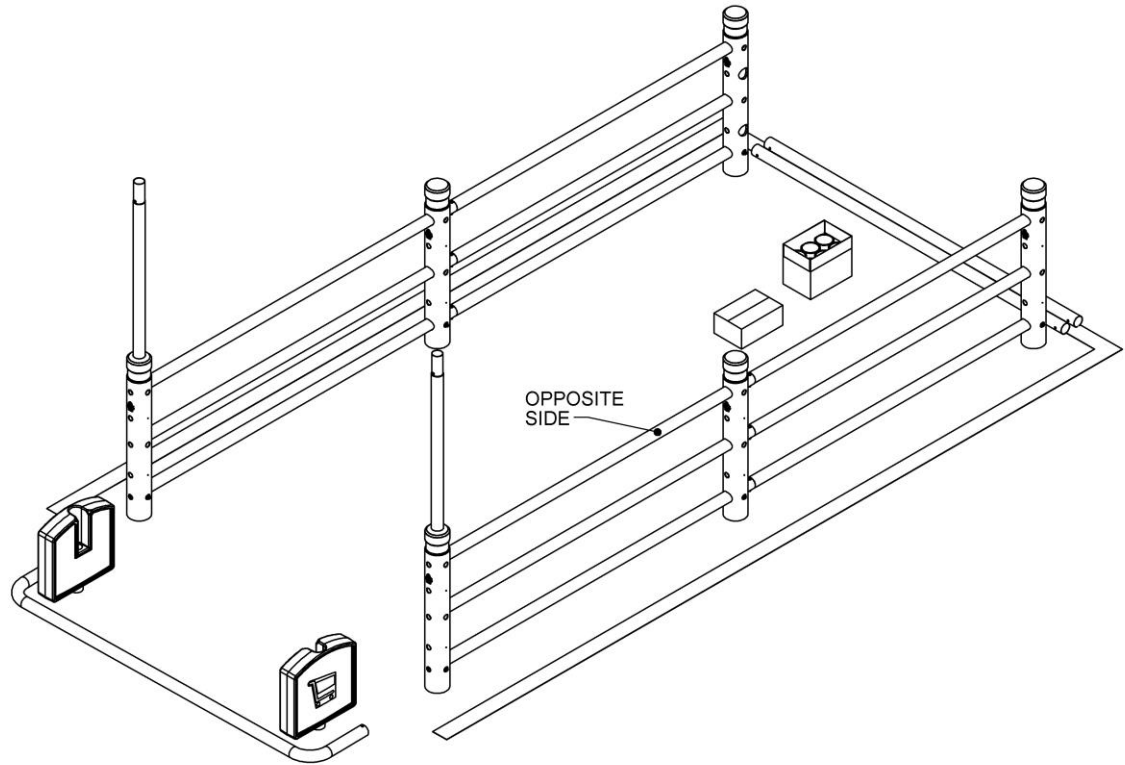



- 07** | **Secure Stopbars to back left and right bollards.**
Slide open ends of Stopbars into the back left and back right bollards. Align holes on stopbar with plastic bollard holes and secure each end with (1) 4" Bolt Assembly. Note: A total of (4) bolt assemblies will be required.

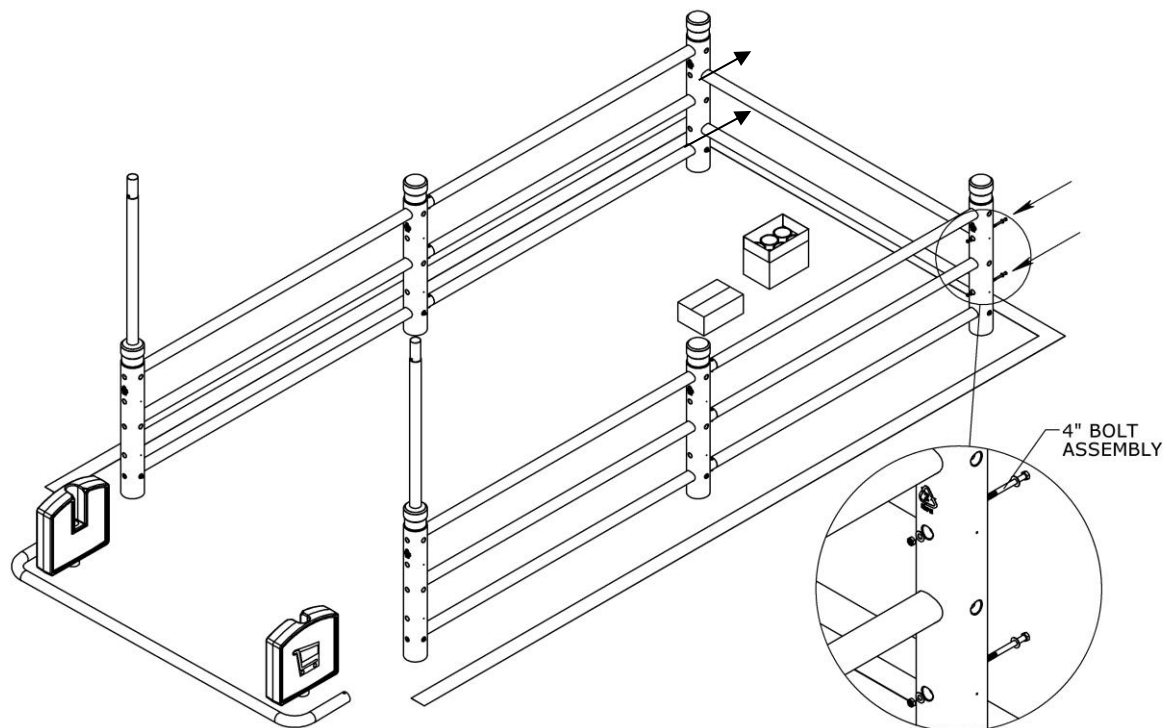



- 08 Slide Signs onto Crossbar**
Slide plastic signs onto crossbar making sure shopping cart logos are facing outside. Slide sign all the way up into the plastic signs.

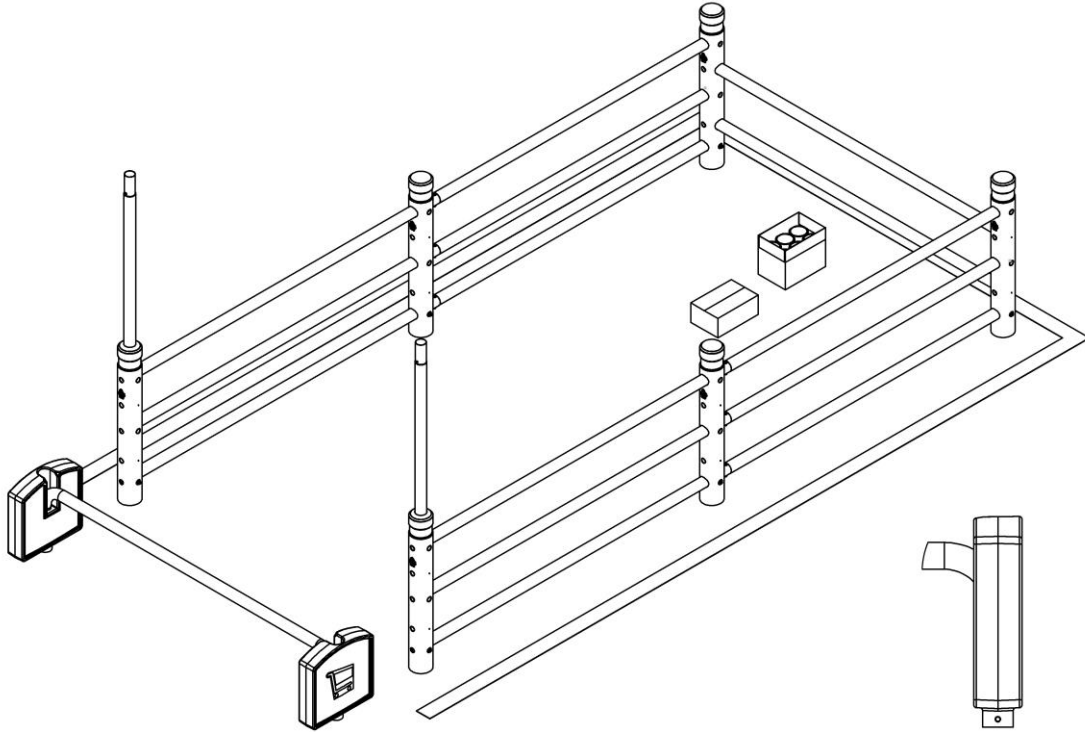



09 Attach Crossbar with Unsecured signs to front of unit.

Lift crossbar with unsecured signs onto the front uprights. Locate Plastic Sign Plumb with unit: Using a level, make sure front uprights are vertical. Locate hole on plastic sign with hole on upright and crossbar as shown in the detail below. Secure each sign to crossbar and uprights with (1) 3-1/2" bolt assembly using a wrench with a 9/16" socket. The bolt should be fully secured.

Note: Do not over tighten bolts and repeat to the other sign.

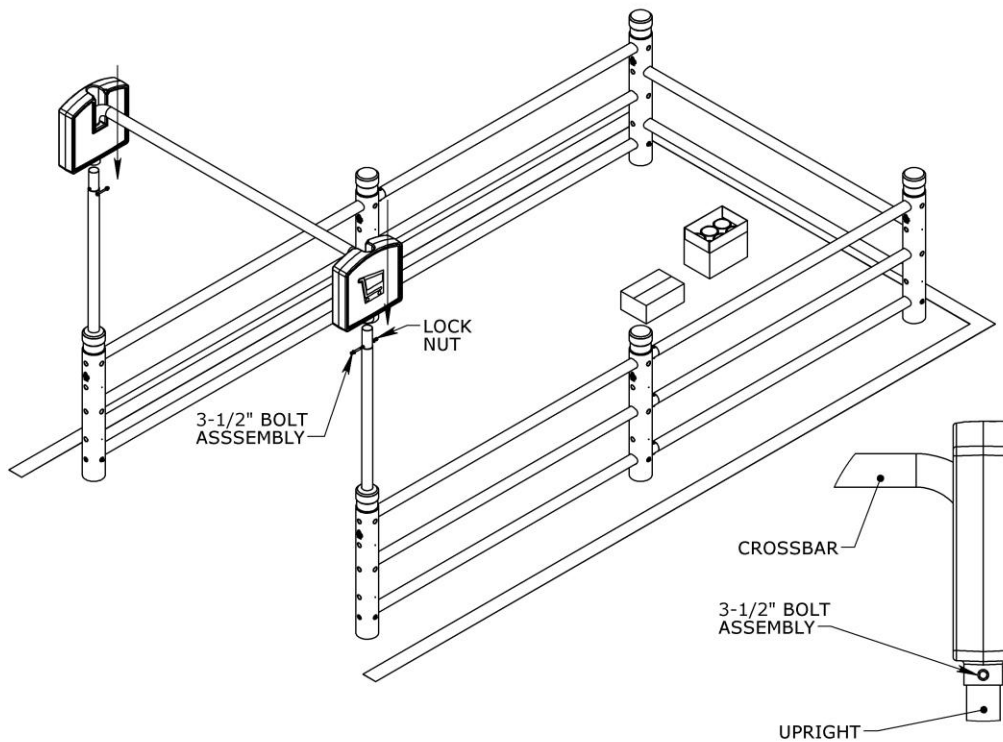



10

Locate unit inside parking space

Space back of unit $4\text{-}\frac{3}{8}\text{'}$ from the inside of the back parking space line and split the width difference on the sides.

Square unit inside parking space

It's very important to square unit before the next step. Square unit by cross measuring and obtaining same measurements across inside to inside of bollards. Make sure that the $81\text{-}\frac{3}{8}\text{'}$ internal bottom dimension between bollards are the same across the front and the back. The internal diagonal dimension across bollards should be $117\text{-}\frac{1}{4}\text{'}$.

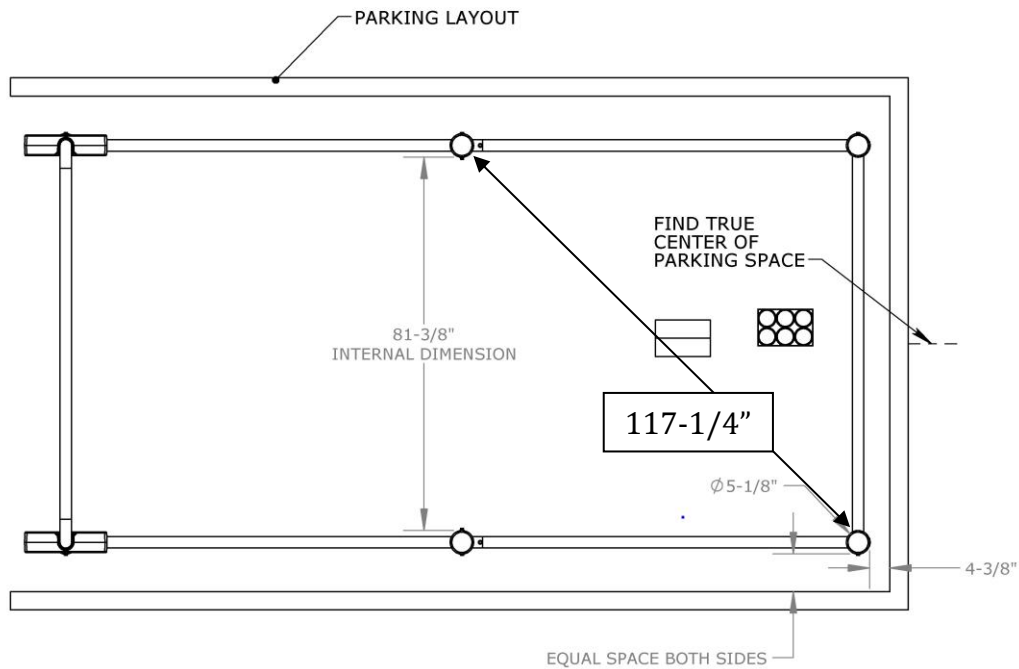



- 11 | **Mark Bollards on asphalt**
Trace bottom of each plastic bollard onto the asphalt with RoseArt Sidewalk chalk Non-Toxic 445, washable.

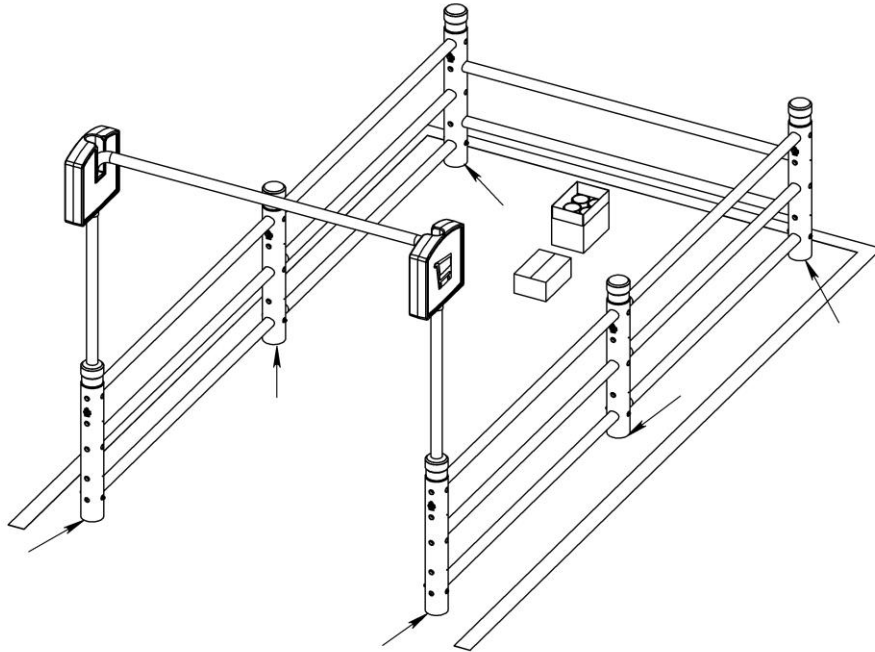

Bollard CartMagnet Standard Open Unit



- 12 **Move unit away from Marks**
Shift entire unit away from marked holes. You may use the steel cup as a guide to find and mark the true center of each of the marks onto the asphalt.

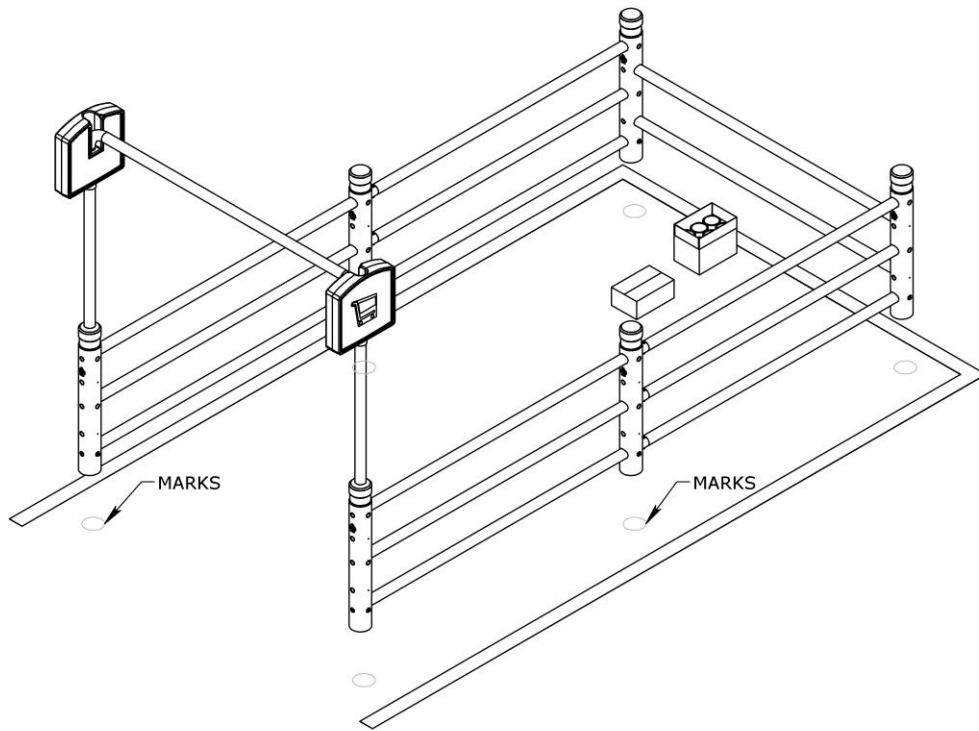



13 Drill 1" diameter holes and insert threaded rods into asphalt

Using an electric hammer drill with a 1" Diameter Carbide bit, drill holes 8" deep into the asphalt at each center mark. To remove all debris around holes, brush and vacuum each hole as necessary. Hole MUST be free of debris for epoxy to properly set. Before opening epoxy, check hole depth to ensure 8" deep.

Important: For installation of anchorage into water filled holes, see recommendation on epoxy manufacture.

It's important not to allow epoxy to expand or build onto the 2" exposed threads of rods above of the asphalt. It can be useful to tape off the top 2" of exposed threads prior to sliding into hole filled with epoxy to prevent this.

Dispense bead of epoxy off to side to assure proper mixing before dispensing. Fill each hole from bottom of hole. Fill each hole with 3.2 oz. epoxy, so that hole is 6" full or 3/4 full. One epoxy tube will be used for three holes. Immediately after dispensing epoxy into one hole, Insert 3/4-10 x 10" Threaded rod, turning clockwise until bottoming out in fixing hole. Note: Work one hole at a time.

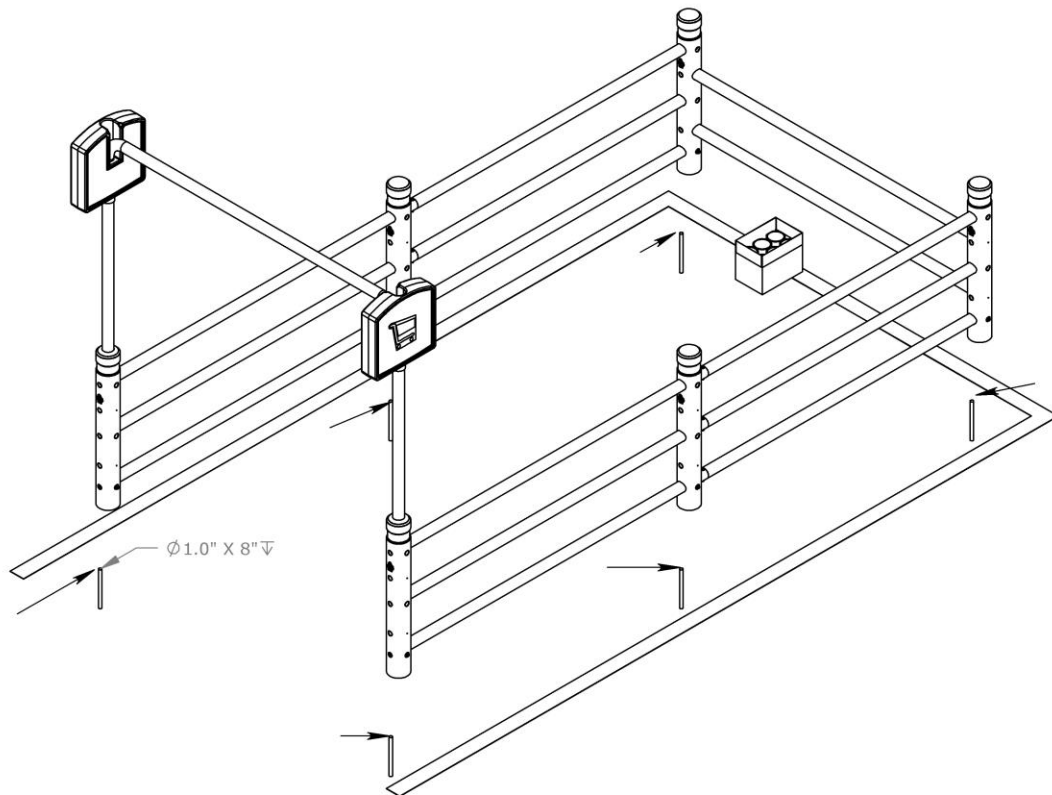



14

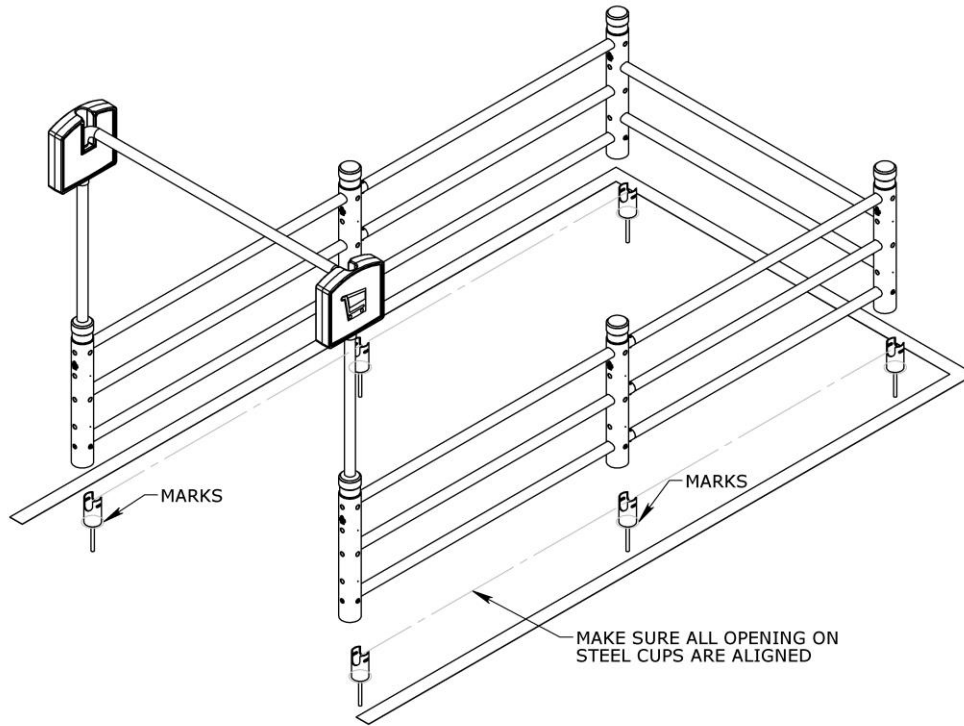

| until fully hardened.

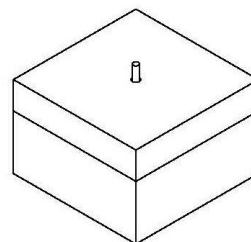
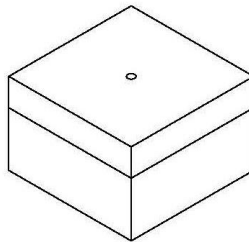
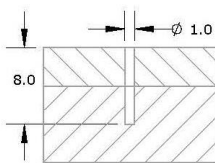



15 Clean marks and secure steel cups

Slide 3/4" ID Flat washer and 3/4-10 nylon lock nut over threaded rod and Hand tighten lock nut.

IMPORTANT: If the threaded rod spins during the tightening process, the hole will need to be drilled out and re-epoxy as described in step 13. Make sure each cup is strongly secured to threaded rod and that it can't be moved or twisted by hand.

Using a torque wrench with an extension and a 1-1/16 deep socket, fasten each steel cup to threaded rod, so that the cup is fully tightened against the asphalt with a maximum of 40 foot/pounds torque, but do not over-tightened.

16 Remove all hand-tightened bottom bolts

Remove all the hand-tightened 5-1/2" bolt assemblies from the bottom of each bollard. Locate unit onto cups by lifting entire unit over and onto each of the cups. **IMPORTANT:** make sure the base of each bollard is flush with asphalt prior to bolting.

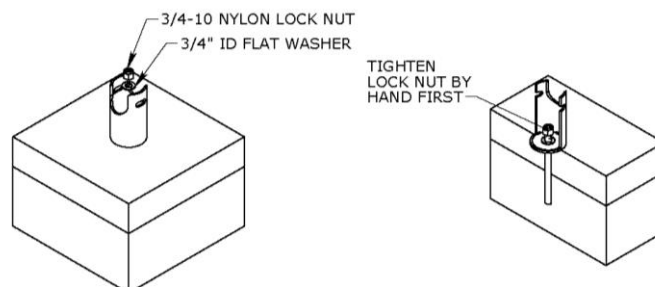

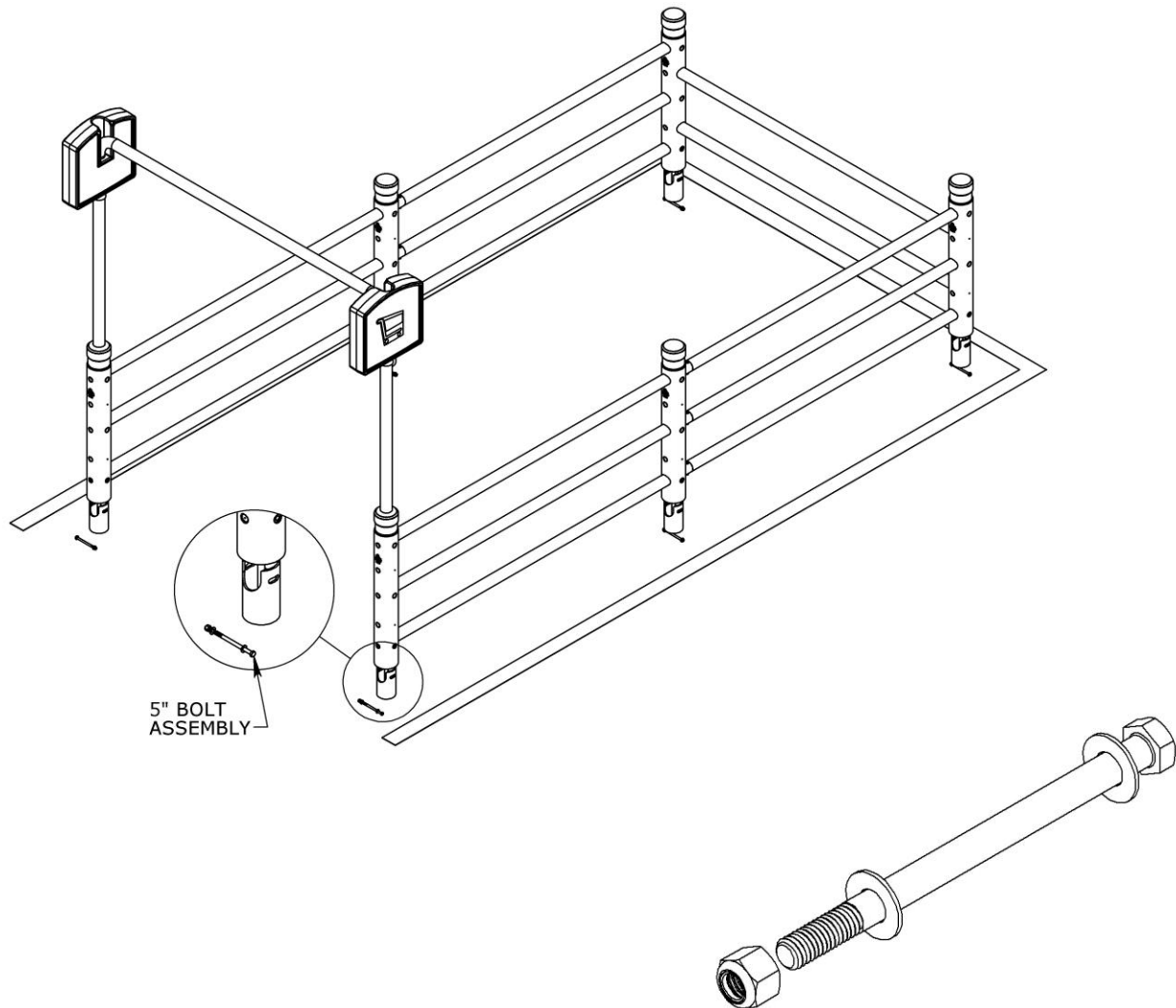

5" BOLT
ASSEMBLY

17

Secure unit to steel cups and add Asset Tag

Secure all plastic bollards to the steel cups using the removed hardware. Locate all the lock nuts facing inside the unit. **IMPORTANT:** the exposed end of bolt must be engaged with the nylon insert on the lock nuts to be fully secured. Attach Asset Tag to the inside bottom right of the left-hand sign.

0111-S01-0314

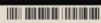



18

Site Supervisor Photograph Unit

SITE SUPERVISOR MUST TAKE (5) PHOTOS OF EACH ASSEMBLED CART CORRAL, "ASSET TAG", "FRONT", "BACK", "RIGHT", "LEFT" VIEW AND UPLOAD PHOTOS ON THE MCCUE PROJECT MANAGEMENT SYSTEM.

NOTE: PLEASE REFER TO RUMBLE STRIP ADDENDUM AND EXECUTE AS NEEDED.

Your Bollard CartMagnet Open unit is now Complete!

