

BumperSign Flex

2022 INSTALLATION INSTRUCTIONS

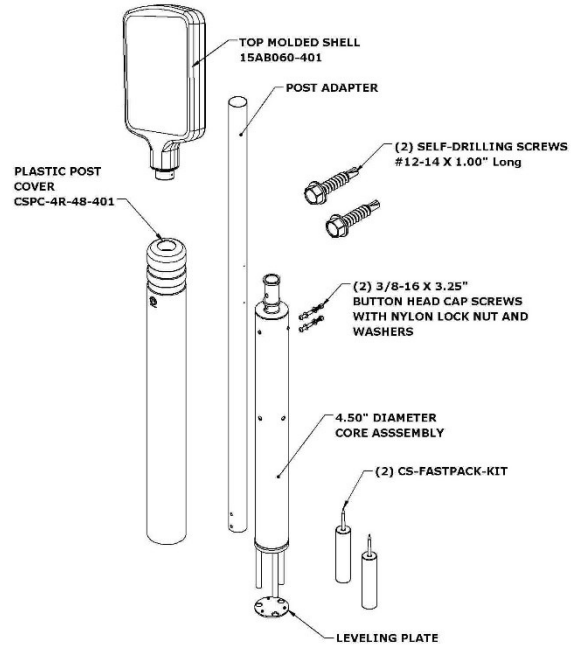

Components



Tools Required

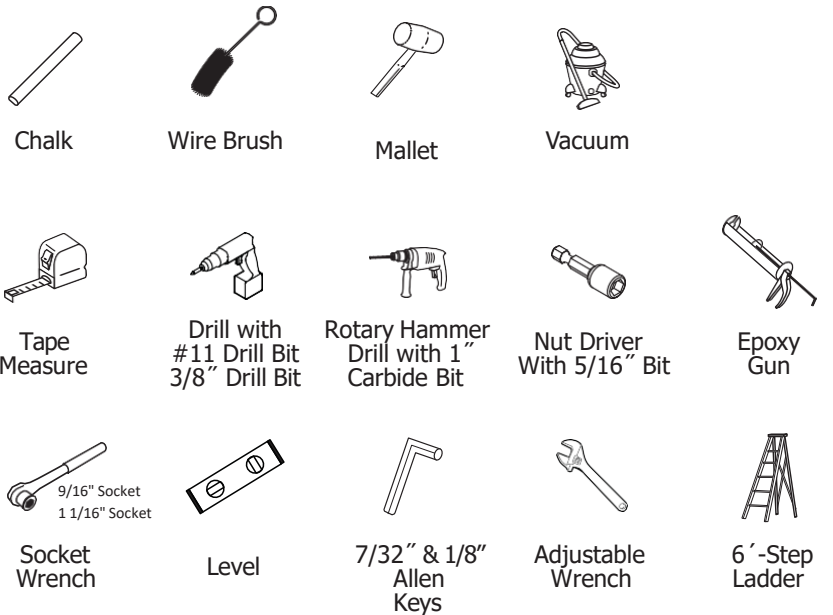

McCue Corporation
 Peabody, Massachusetts, USA
 +1 (800) 800 8503
customer-care@mccue.com

McCue UK & Europe
 Milnort Keynes, United Kingdom
 +44 (0)1908 365 511
uksales@mccue.com

McCue Asia
 迈客(厦门)有限公司
 Xiamen, Fujian, China
 +86-592-2200790

mccue.com





1

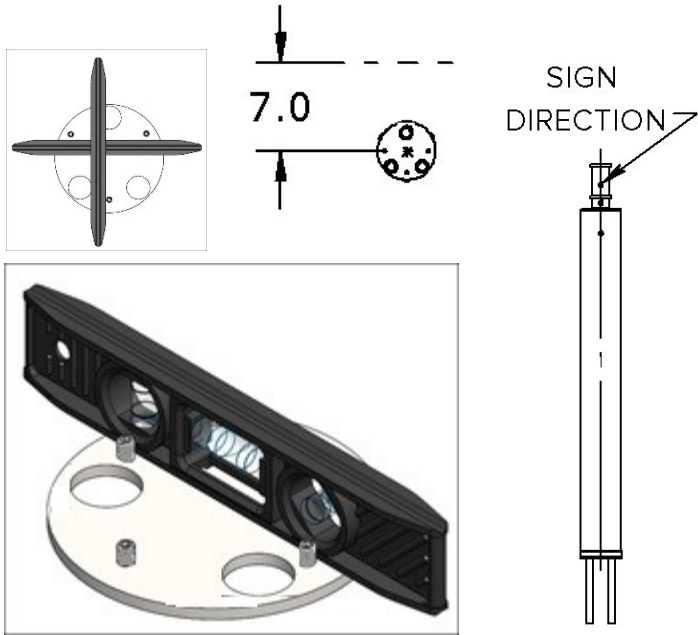

+ Position 7" away from any concrete or asphalt edges. Two holes should be horizontal and parallel to the direction of the sign. Level plate on both directions by adjusting set screws with an 1/8" Allen key. Make sure the plate is firm and does not rock.

2

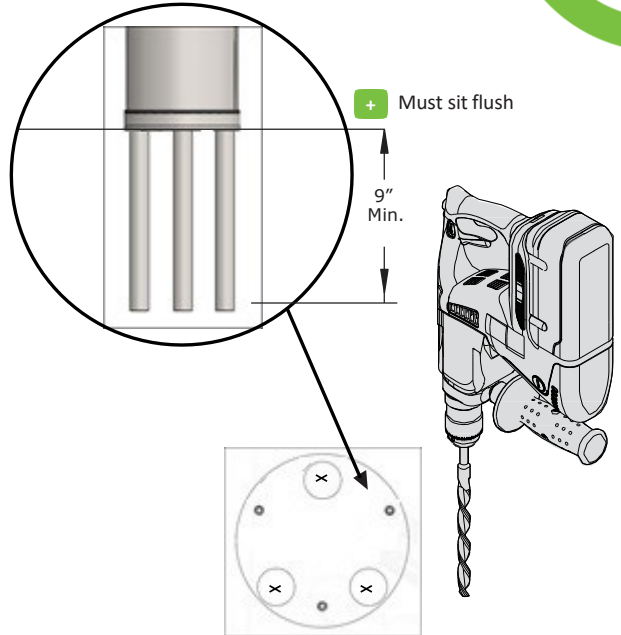

+ Must sit flush
9" Min.
Using the leveling plate as a template, Rotary Hammer Drill with 1" Carbide Bit, drill (3) 9" deep holes. Do a dry fit on the system prior to step 3.

3

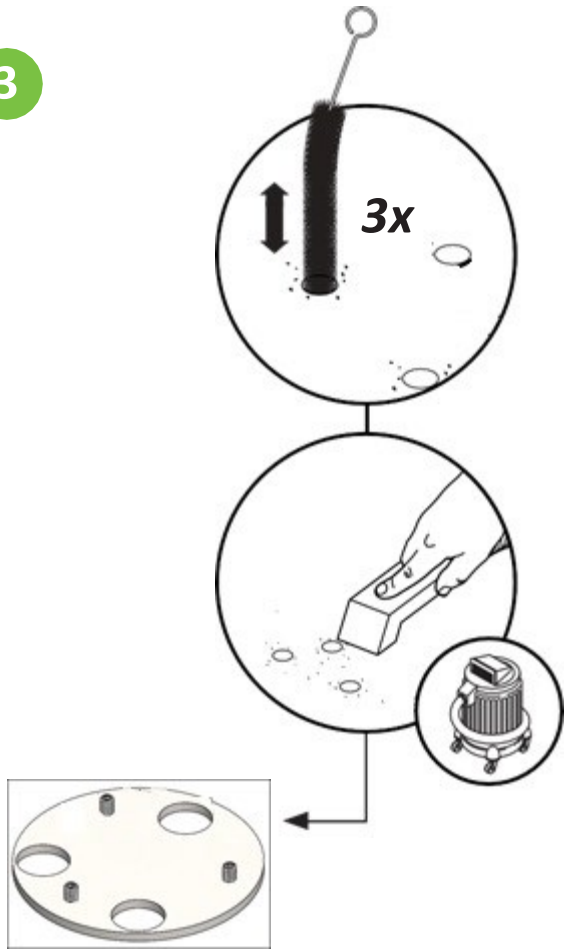

4



Attention:
This is a time sensitive step

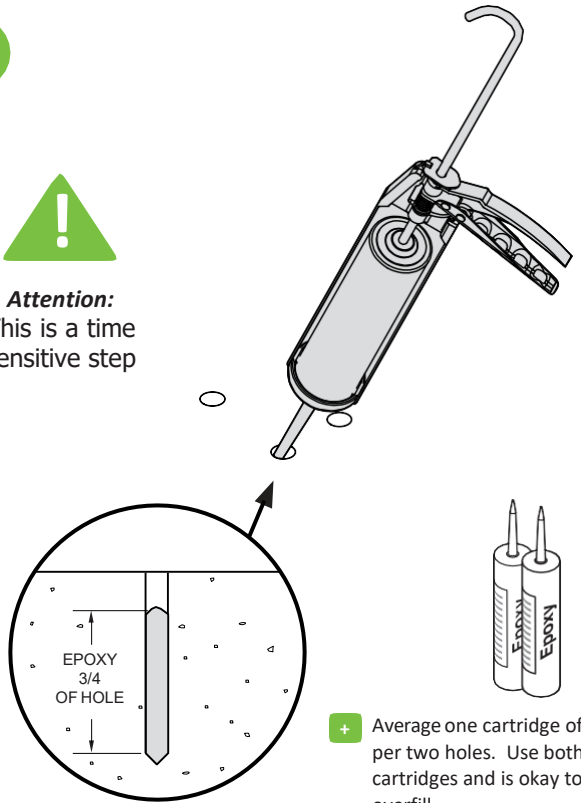

+ Average one cartridge of epoxy per two holes. Use both cartridges and is okay to have overflow.



5

+ Slide into epoxy and must sit flush to ground plate, use mallet if necessary. Once flush, allow epoxy to harden and avoid moving.

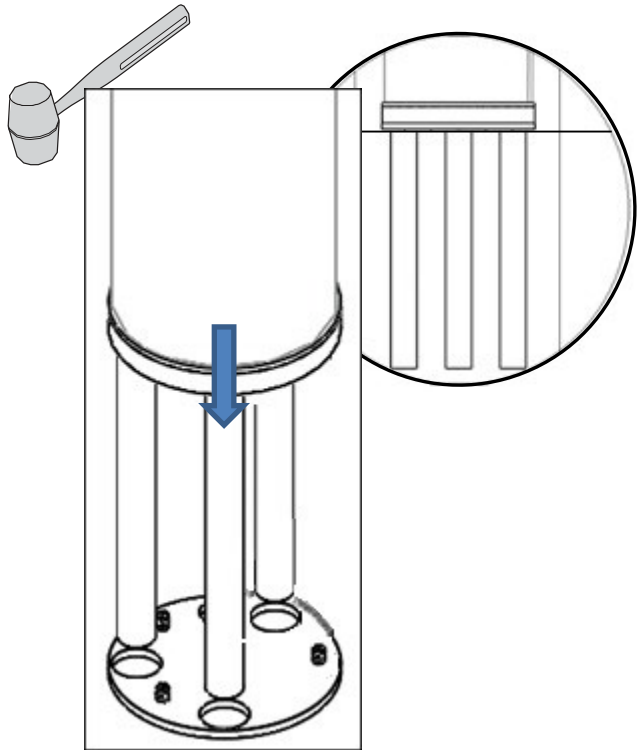

6

+ Clean away excess epoxy. Follow epoxy instructions for recommended cure times.



7

+ Slide post adapter into core and secure with (2) 3/8-16 x 3.25" long bolts, with washers and lock nuts until tight.

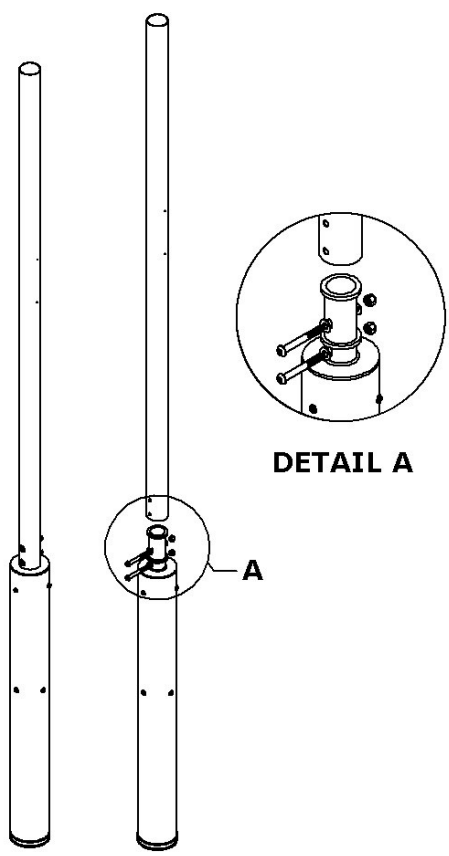

8

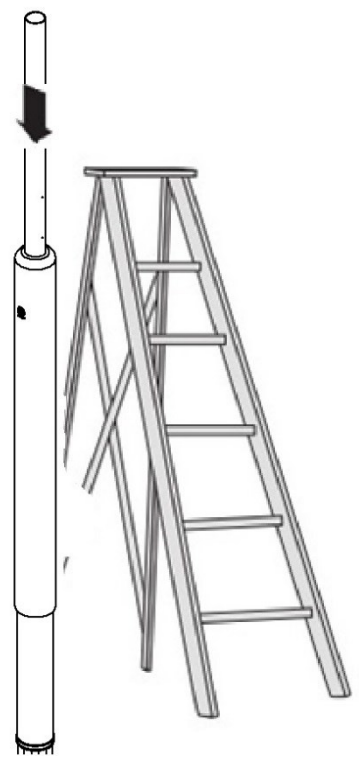

9

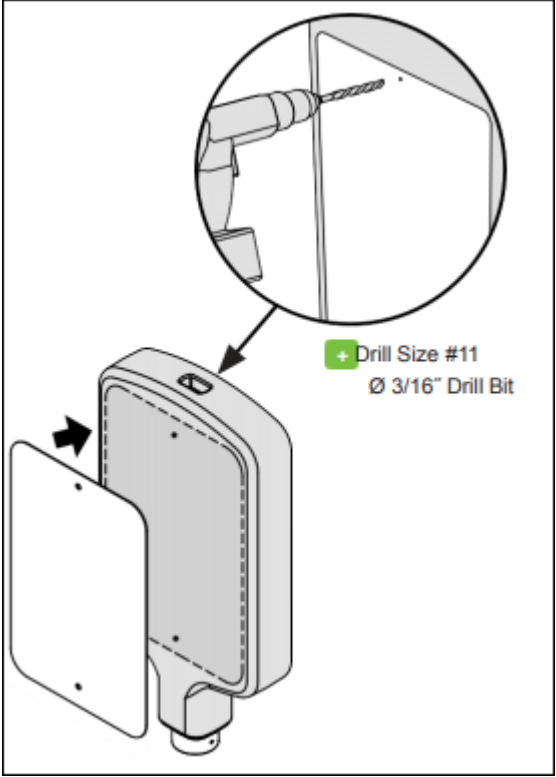

10

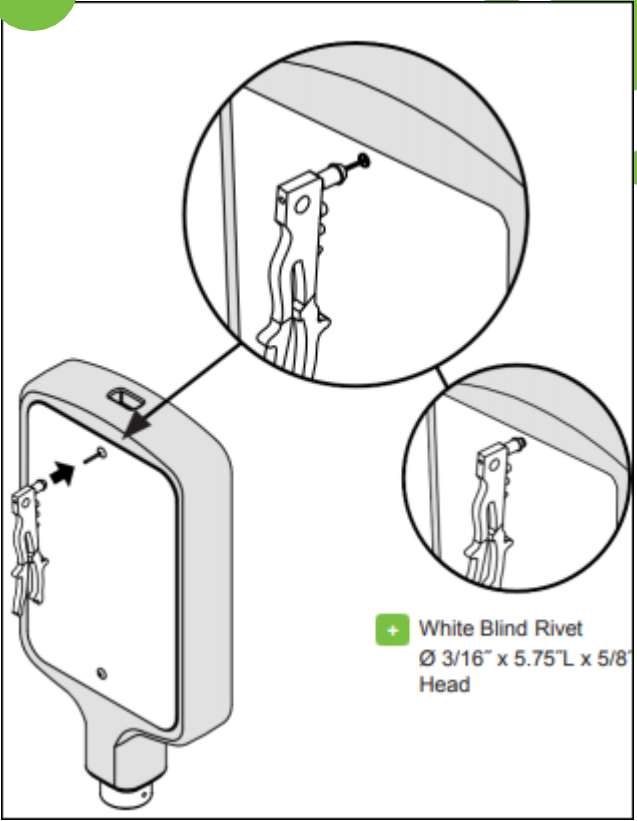

11



Attention:
Make sure the sign front and lower shell is aligned

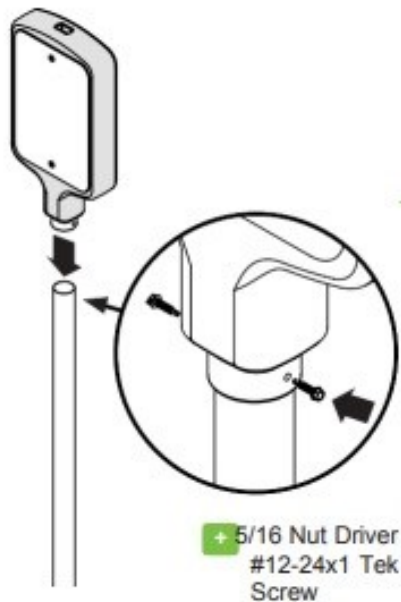

12

