

# BUMPER SIGN MOBILE

## BSM-###

### INSTALLATION INSTRUCTIONS

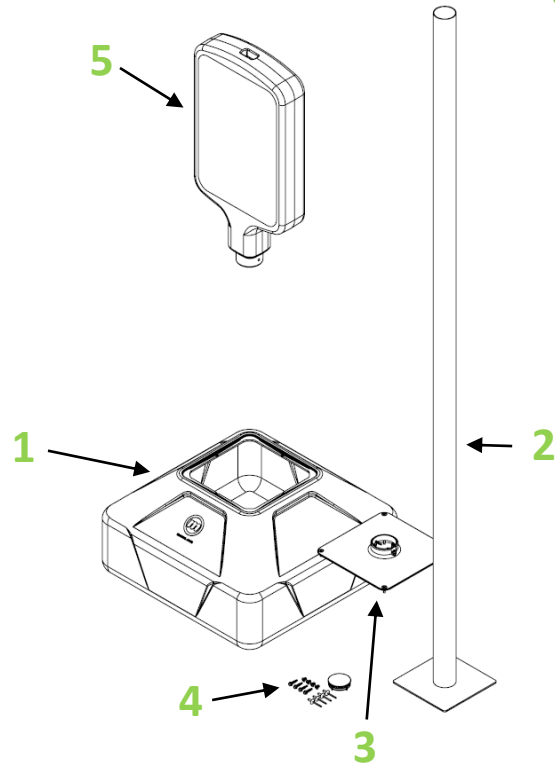
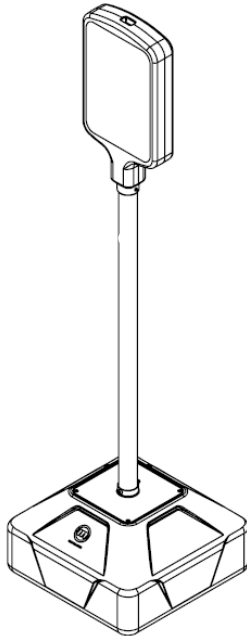

#### Components

ITEM #	PART #	DESCRIPTION	QTY
1	BSM-BASE-###	BUMPERSIGN MOBILE POUR IN SIGN BASE	1
2	BSM-POST	BUMPERSIGN MOBILE POST	1
3	BSM-CAP-###	BUMPERSIGN MOBILE CAP	1
4	BSM-HARDWARE	BUMPERSIGN MOBILE HARDWARE KIT	1
5	15AB060-###	BS TOP MOLDED SHELL	1

#### Tools Required



Drill with  
#11 Drill Bit  
3/8" Drill Bit

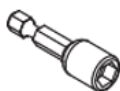

NUT DRIVER  
WITH 5/16" BIT

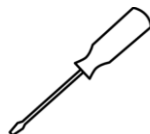

SCREWDRIVER



RIVET GUN



7/32" ALLEN KEY



**McCue Corporation**  
Peabody, Massachusetts, USA  
+1 (800) 800 8503  
[customer-care@mccue.com](mailto:customer-care@mccue.com)

**McCue UK & Europe**  
Milton Keynes, United Kingdom  
+44 (0)1908 365 511  
[uksales@mccue.com](mailto:uksales@mccue.com)

**McCue Asia**  
迈客(厦门)有限公司  
Xiamen, Fujian, China  
+86-592-2200790

[mccue.com](http://mccue.com)



1

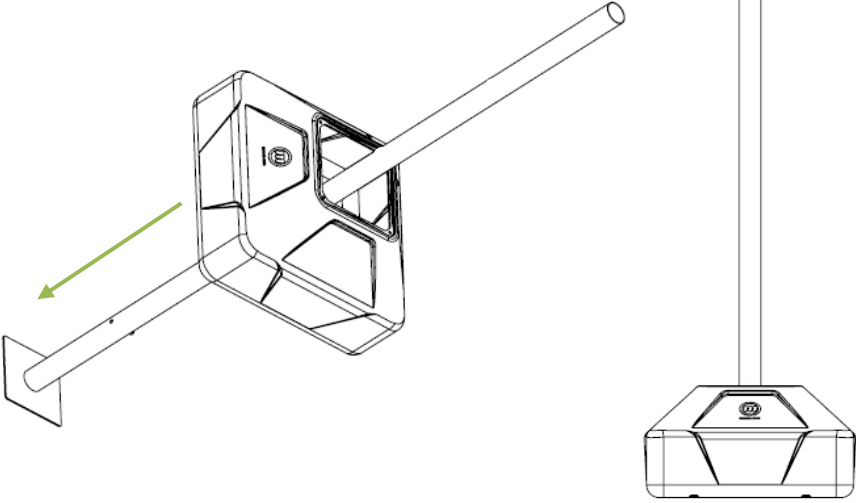

- Slide base over post.

2

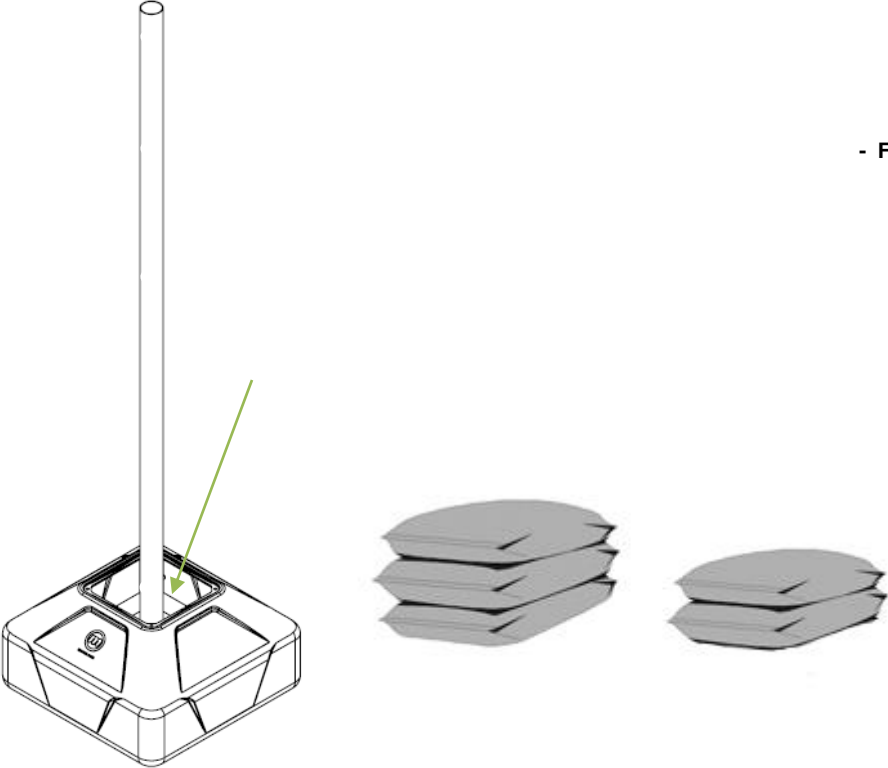

- Fill base with 250LBs of crushed Stone.

3

- Slide cover over post and into place.

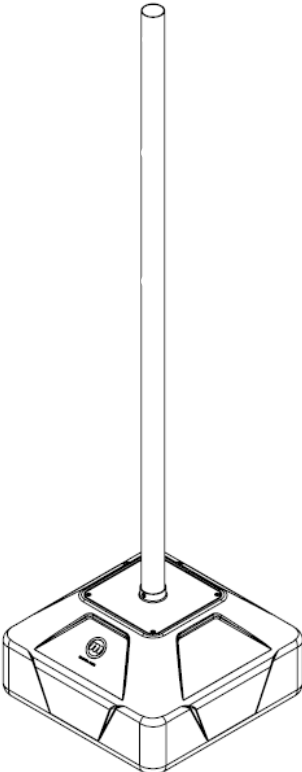

4

- Using Thread lock and the 4 Flathead Screws, secure the cap to the base.

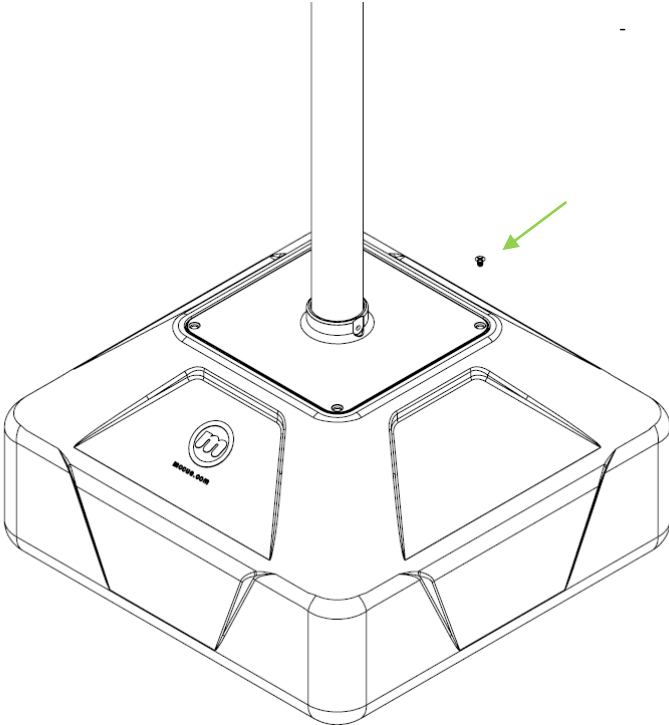

5

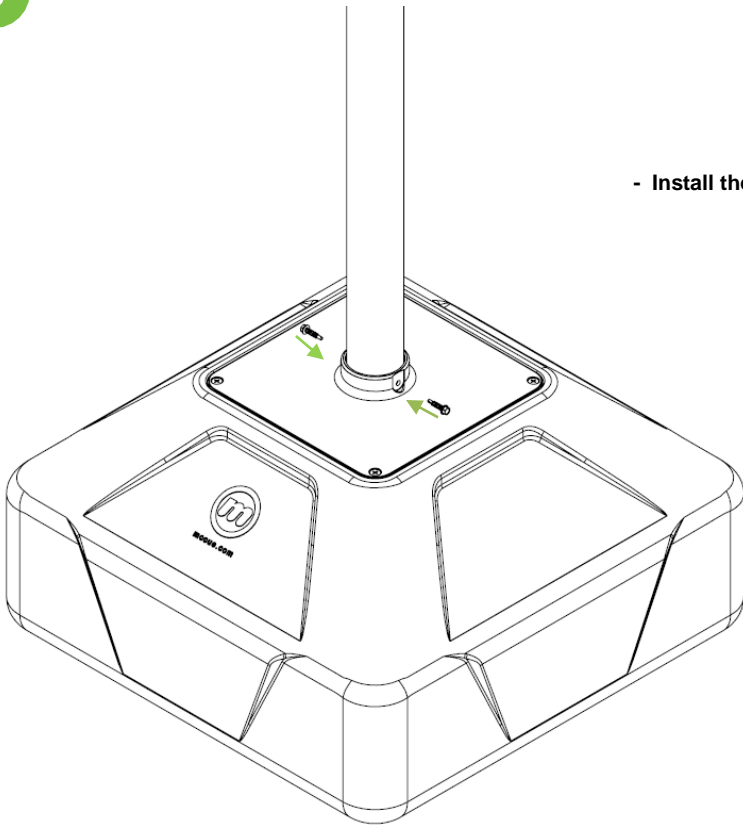

- Install the 2 self drilling screws through the Cap and into the Signpost

6

### Install placards

Note : Placards not included

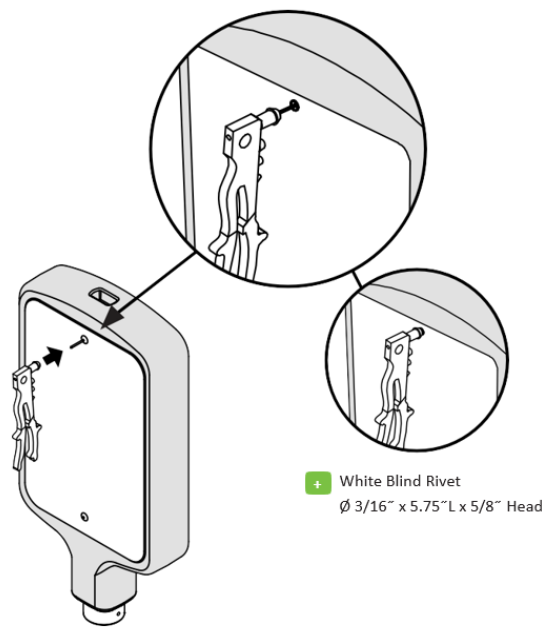
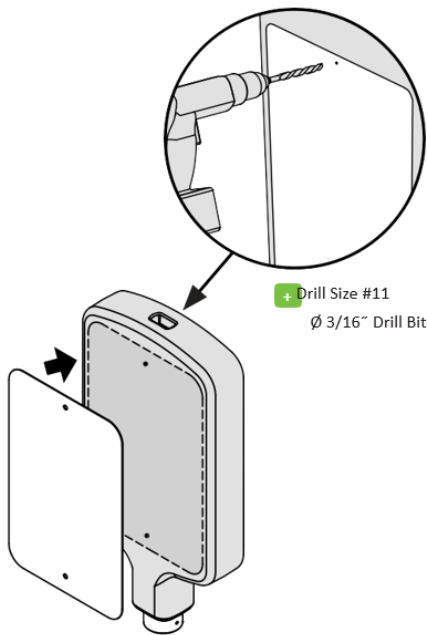

7

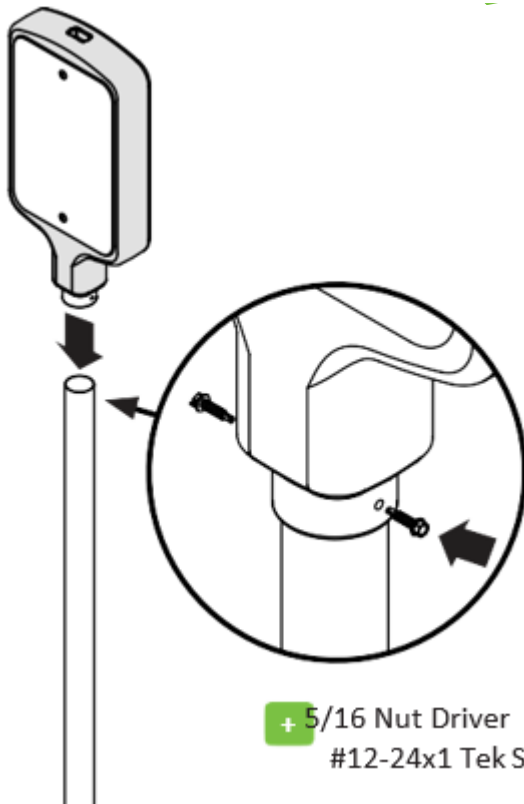

- Slide the Bumper sign topper over the post and secure using the 2 provided self drilling screws.

