

# BUMPER SIGN MOBILE

## BSM-NT-###

### INSTALLATION INSTRUCTIONS

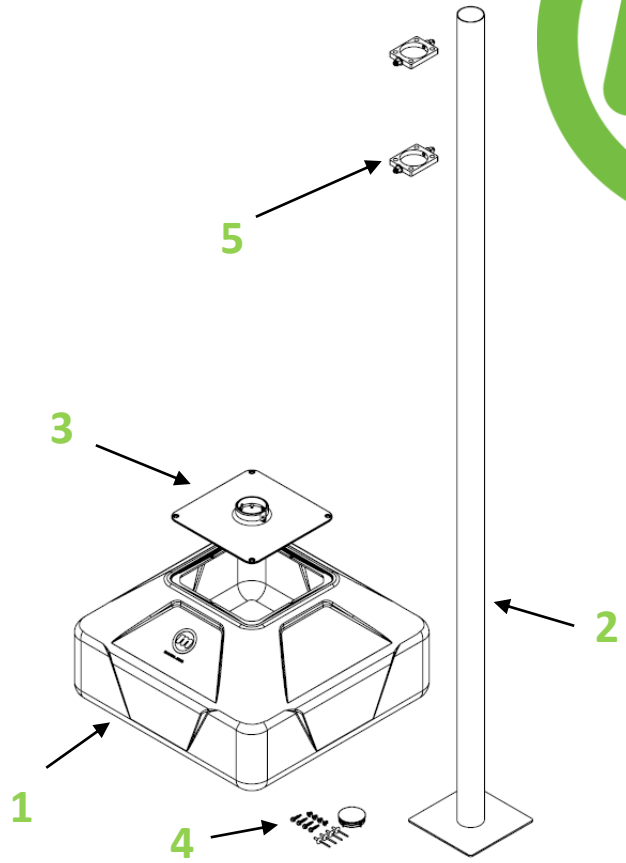
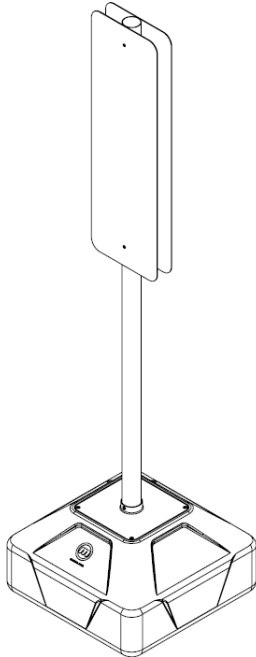

\*Placards not included\*

#### Components

ITEM #	PART #	DESCRIPTION	QTY	REV
1	BSM-BASE-###	BUMPERSIGN MOBILE POUR IN SIGN BASE	1	A
2	BSM-POST	BUMPERSIGN MOBILE POST	1	B
3	BSM-PLCAP-###	BUMPERSIGN MOBILE PLASTIC CAP	1	2
4	BSM-HARDWARE	BUMPERSIGN MOBILE HARDWARE KIT	1	B
5	15AA617	UNIVERSAL BRACKET KIT FOR PLACARDS	1	A

#### Tools Required



SCREWDRIVER

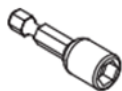

NUT DRIVER  
WITH 5/16" BIT



MALLET

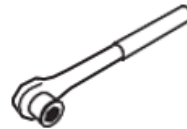

SOCKET WRENCH  
WITH 9/16" SOCKET



7/32" ALLEN KEY



3/16" ALLEN KEY



Questions

**McCue Corporation**  
Peabody, Massachusetts, USA  
+1 (800) 800 8503  
[customercare@mccue.com](mailto:customercare@mccue.com)

**McCue UK & Europe**  
Milton Keynes, United Kingdom  
+44 (0)1908 365 511  
[uksales@mccue.com](mailto:uksales@mccue.com)

**McCue Asia**  
迈客(厦门)有限公司  
Xiamen, Fujian, China  
+86-592-2200790

[mccue.com](http://mccue.com)





1

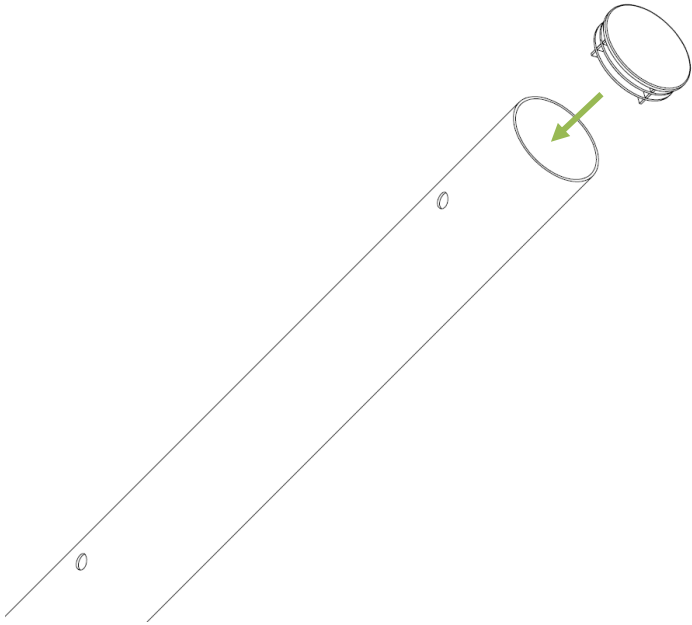

- Tap plug into post.

2

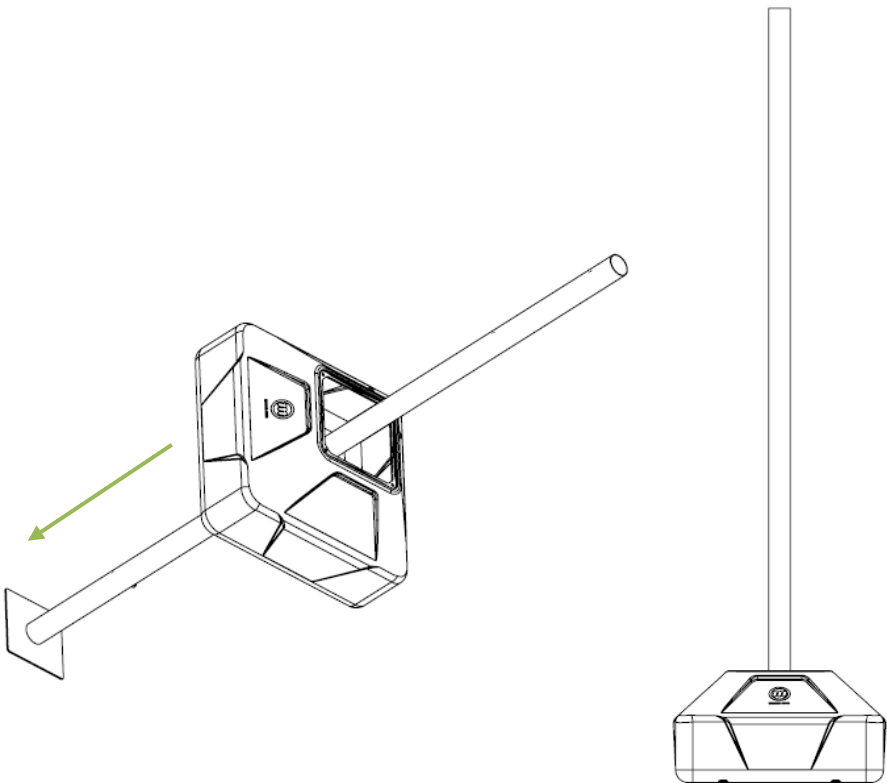

- Slide base over post.



3

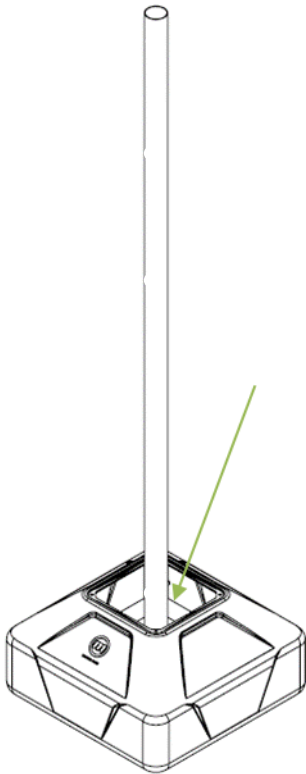

- Fill base with 250LBs of crushed Stone.

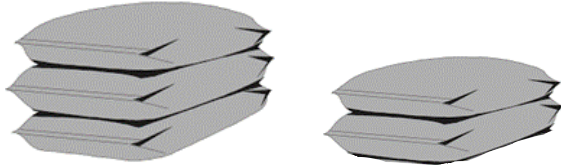

4

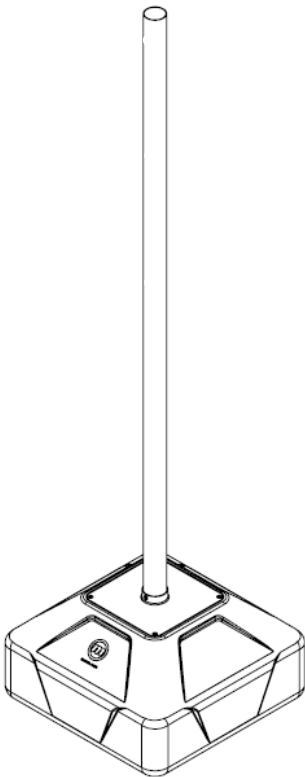

- Slide cover over post and into place.



5

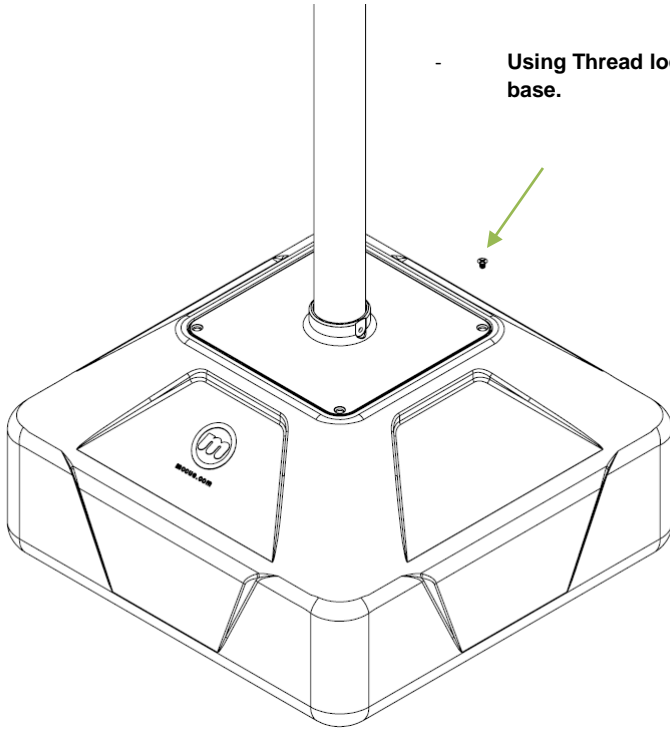

- Using Thread lock and the 4 Flathead Screws, secure the cap to the base.

6

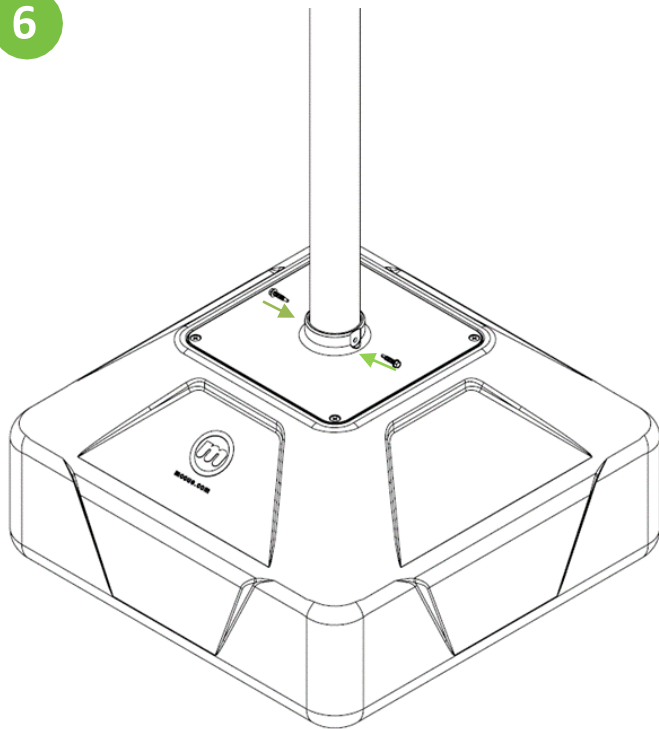

- Install the 2 self drilling screws through the Cap and into the Signpost.



7

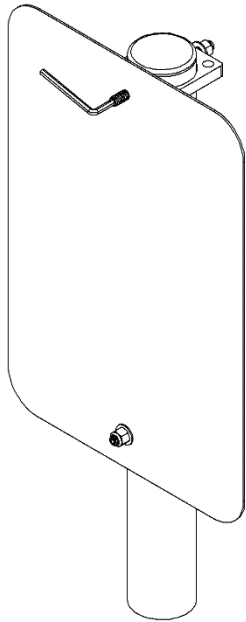

**Attention:**  
Must be  
tightened

Slide brackets to round post that has a 2-1/2" outside Diameter. Locate as desire and tighten set screws clockwise into post using 3/16" Allen Key. Opposite set screw can be also tightened. Make sure is tight against post and that bracket will not move.

8

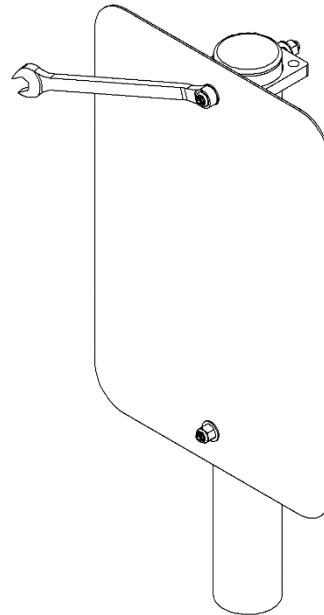

+ Must be  
tightened

Slide flat washer and nylon lock nut onto set screw. Using a 9/16" open wrench tighten lock nuts until sign is tight to bracket.

9

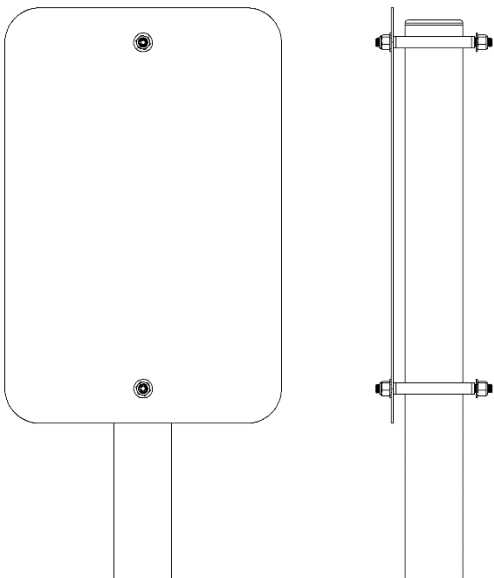

10

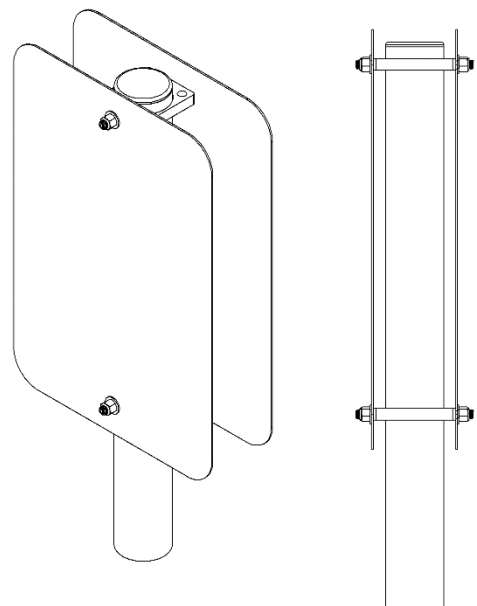

+ Optional back-to-back signs installation.