

BUMPER SIGN MOBILE

BSM-###

INSTALLATION INSTRUCTIONS

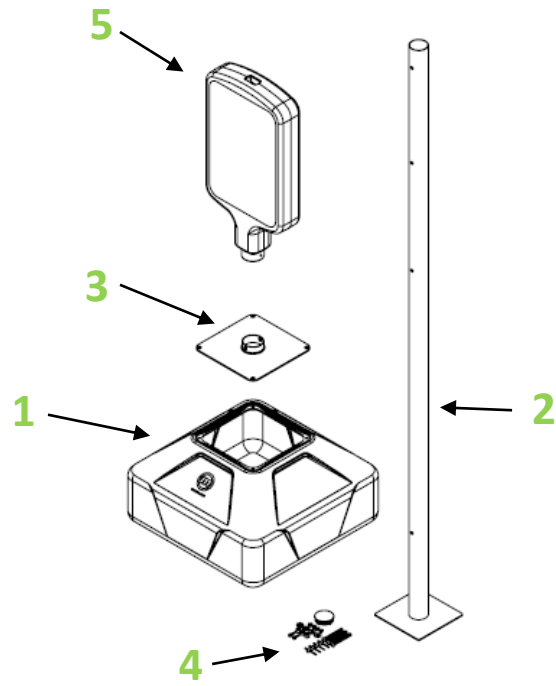
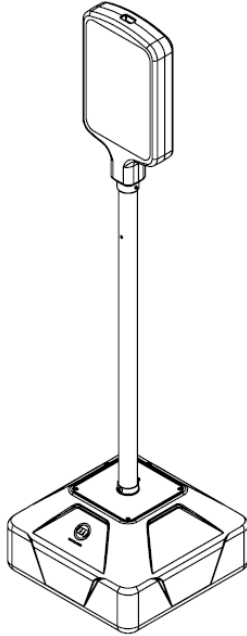

Components

Note : Not all hardware components provided will be used.

| ITEM # | PART # | DESCRIPTION | QTY |
|--------|--------------|-------------------------------------|-----|
| 1 | BSM-BASE-### | BUMPERSIGN MOBILE POUR IN SIGN BASE | 1 |
| 2 | BSM-POST | BUMPERSIGN MOBILE POST | 1 |
| 3 | BSM-CAP-### | BUMPERSIGN MOBILE CAP | 1 |
| 4 | BSM-HARDWARE | BUMPERSIGN MOBILE HARDWARE KIT | 1 |
| 5 | 15AB060-### | BS TOP MOLDED SHELL | 1 |

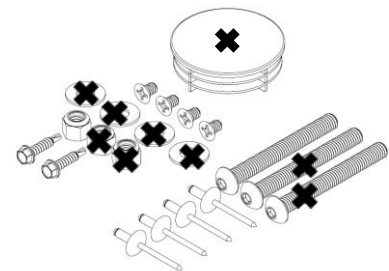

Tools Required



Drill with
#11 Drill Bit
3/8" Drill Bit

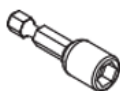

NUT DRIVER
WITH 5/16" BIT



SCREWDRIVER



RIVET GUN



SOCKET WRENCH
WITH 9/16" SOCKET



7/32" ALLEN KEY



McCue Corporation
Peabody, Massachusetts, USA
+1 (800) 800 8503
customer care@mccue.com

McCue UK & Europe
Milton Keynes, United Kingdom
+44 (0)1908 365 511
uksales@mccue.com

McCue Asia
迈客(厦门)有限公司
Xiamen, Fujian, China
+86-592-2200790

mccue.com



1

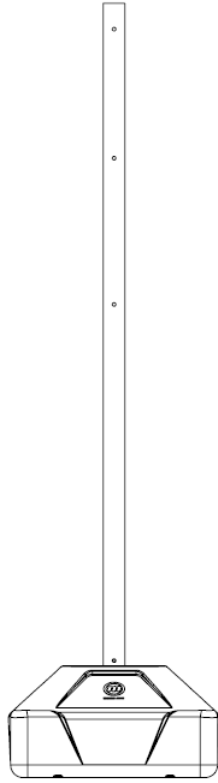
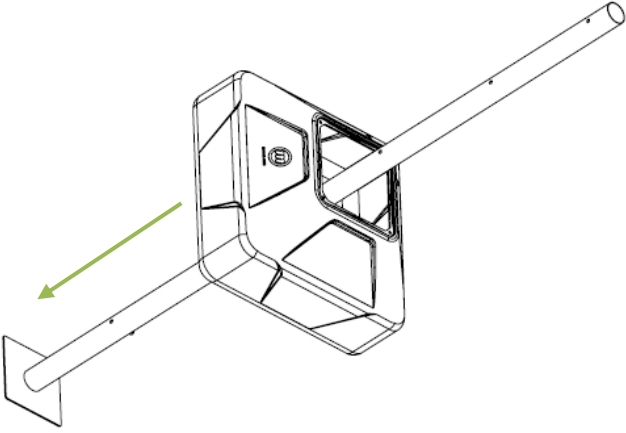

- Slide base over post

2

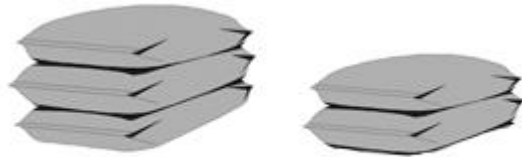
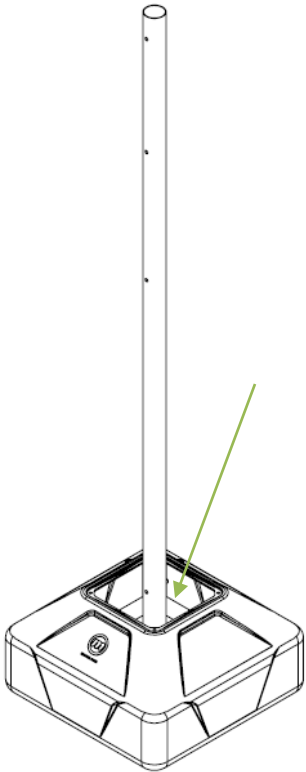

- Fill base with 250LBs of crushed Stone

3

- Slide cover over post and into place

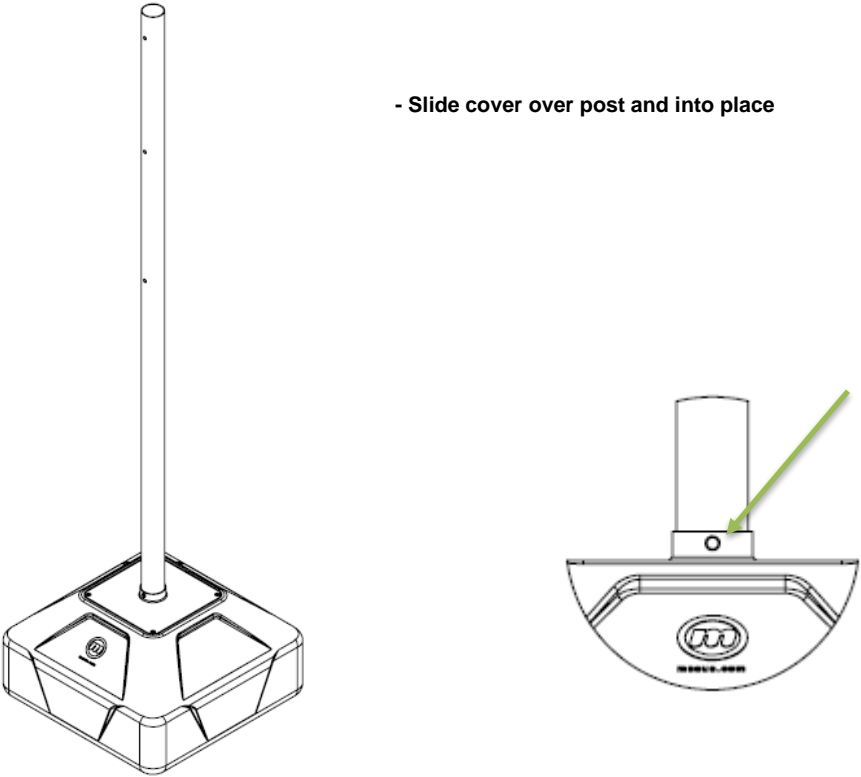

4

- Secure the cover to the base with 4 flat head screws

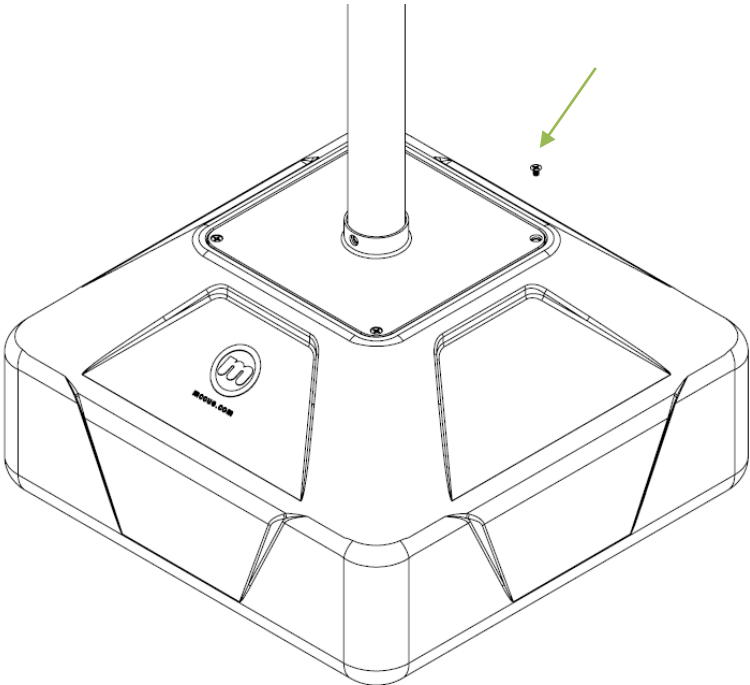

5

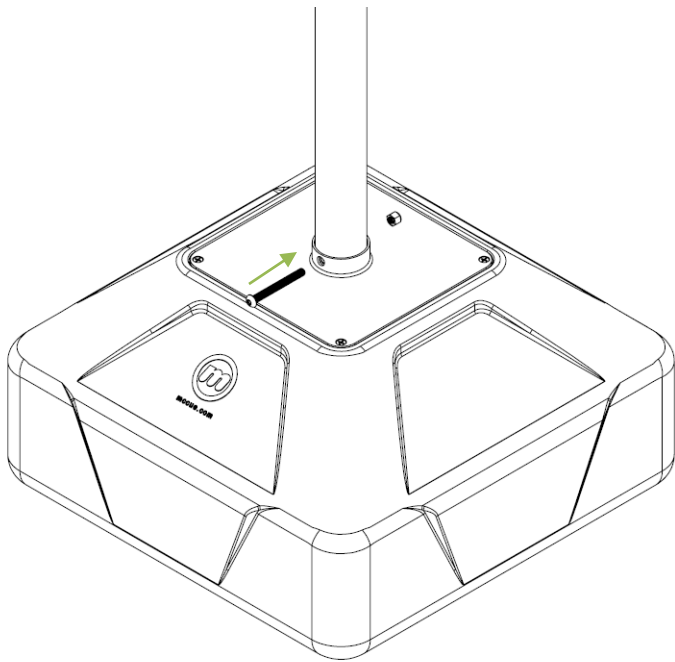

- Insert the 3/8" bolt through the cover and post and secure with a lock nut on the other side.

6

Install placards

Note : Placards not included

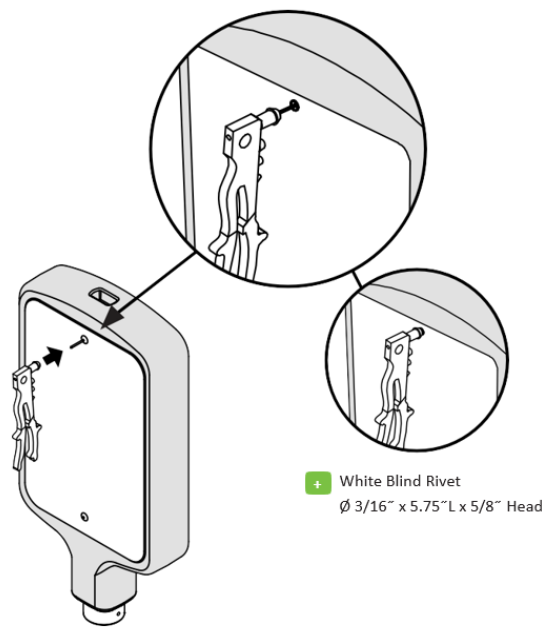
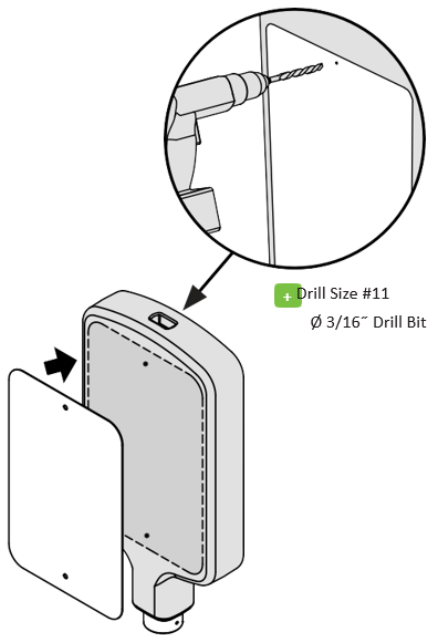

7

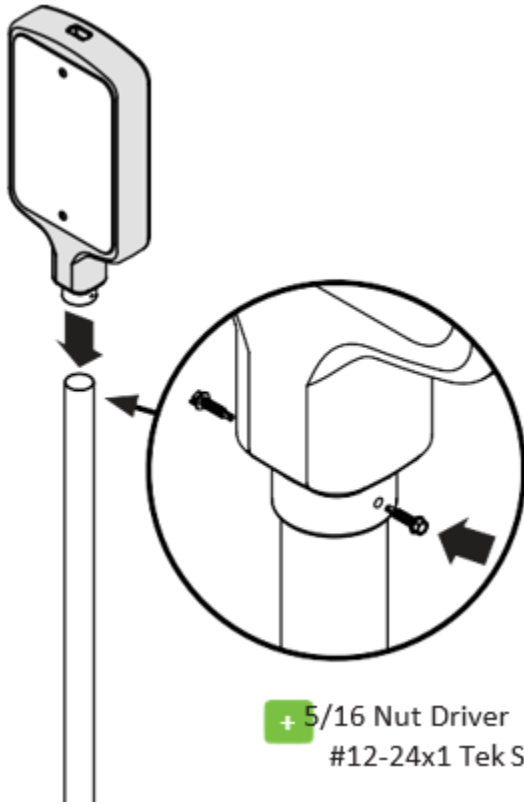

- Slide the Bumper sign topper over the post and secure using the 2 provided self drilling screws.

