

BUMPER SIGN MOBILE

BSM-NT-###

INSTALLATION INSTRUCTIONS

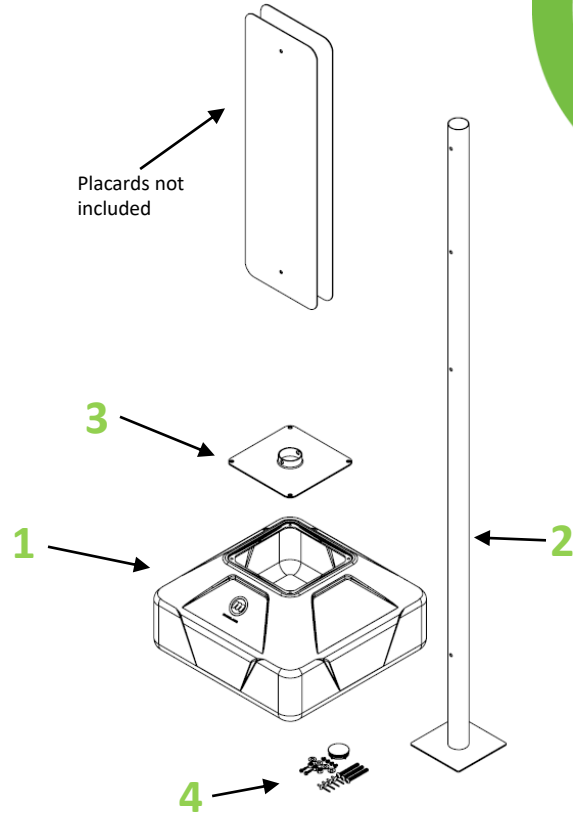
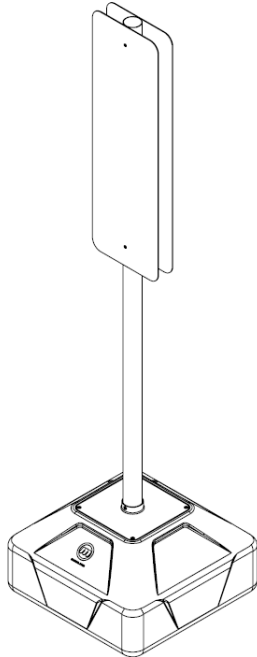

Components

Note : Not all hardware components provided will be used.

ITEM #	PART #	DESCRIPTION	QTY
1	BSM-BASE-###	BUMPERSIGN MOBILE POUR IN SIGN BASE	1
2	BSM-POST	BUMPERSIGN MOBILE POST	1
3	BSM-CAP-###	BUMPERSIGN MOBILE CAP	1
4	BSM-HARDWARE	BUMPERSIGN MOBILE HARDWARE KIT	1

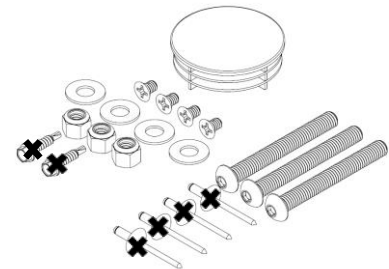

Tools Required



SCREWDRIVER



MALLET



SOCKET WRENCH
WITH 9/16" SOCKET



7/32" ALLEN KEY



McCue Corporation
Peabody, Massachusetts, USA
+1 (800) 800 8503
customercare@mccue.com

McCue UK & Europe
Milton Keynes, United Kingdom
+44 (0)1908 365 511
uksales@mccue.com

McCue Asia
迈客(厦门)有限公司
Xiamen, Fujian, China
+86-592-2200790

mccue.com



1

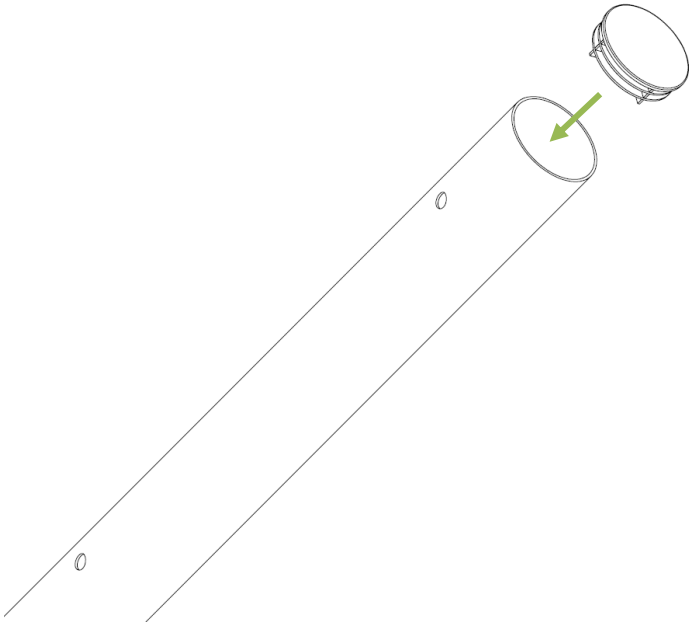

- Tap plug into post

2

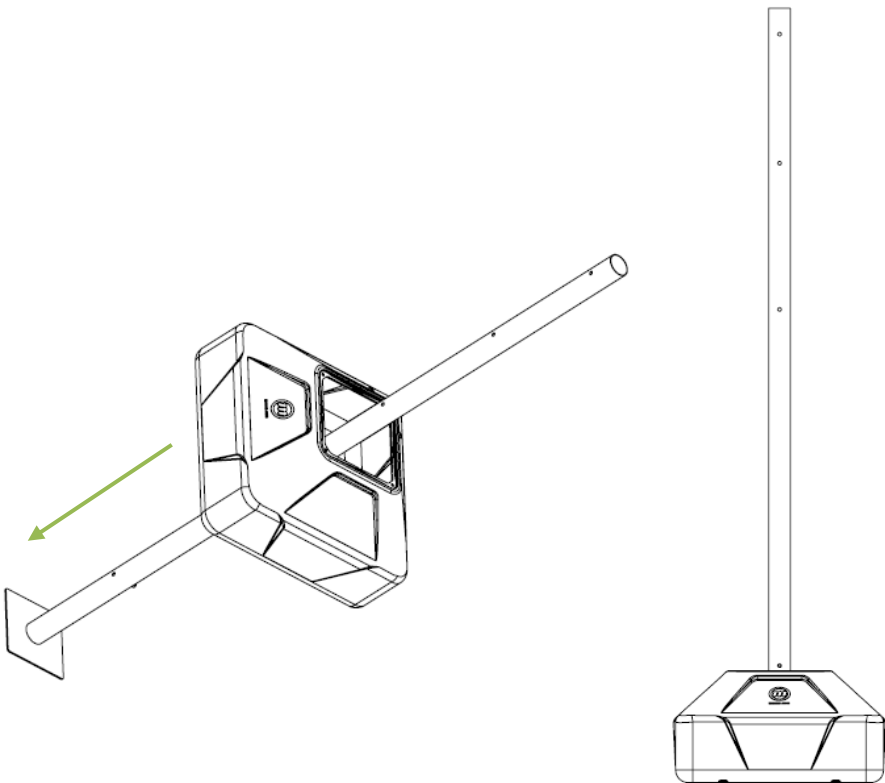

- Slide base over post

3

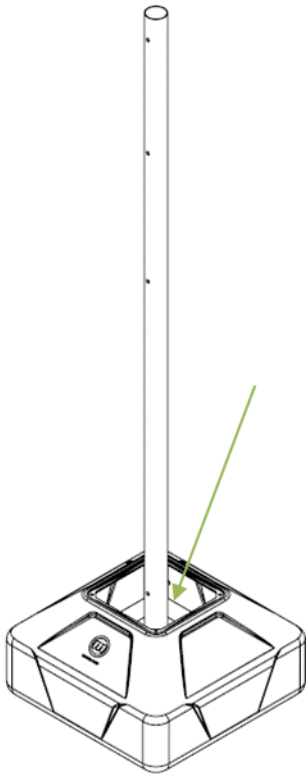

- Fill base with 250LBs of crushed Stone

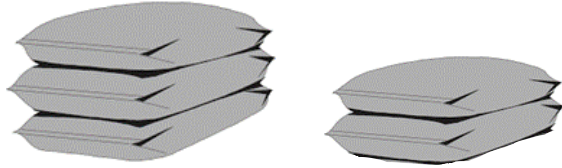

4

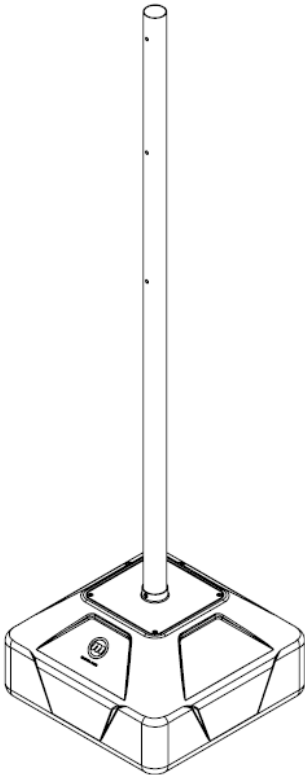

- Slide cover over post and into place

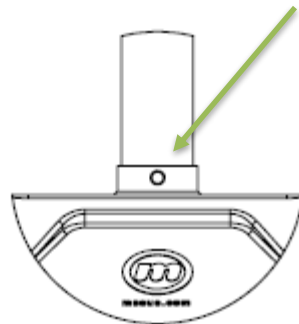

5

- Secure the cover to the base with 4 flat head screws

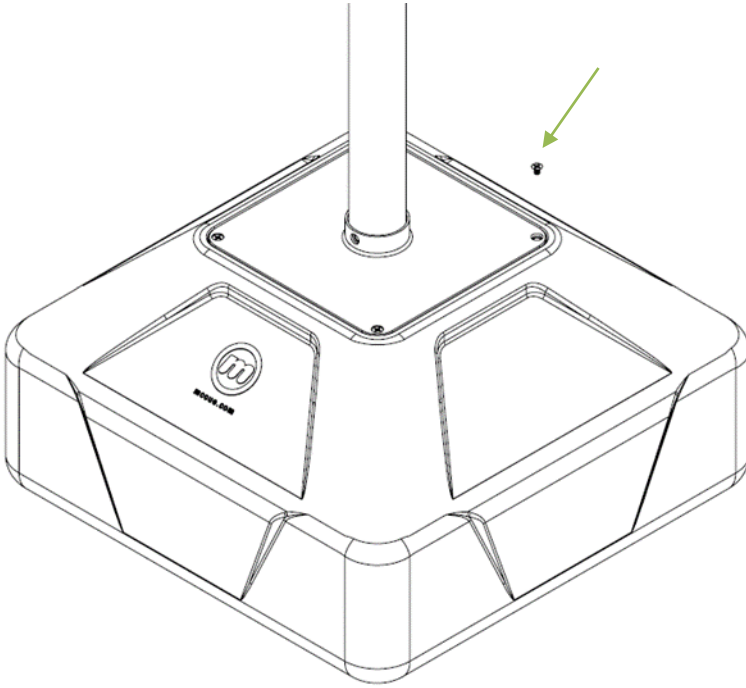

6

- Insert the 3/8" bolt through the cover and post and secure with a lock nut on the other side.

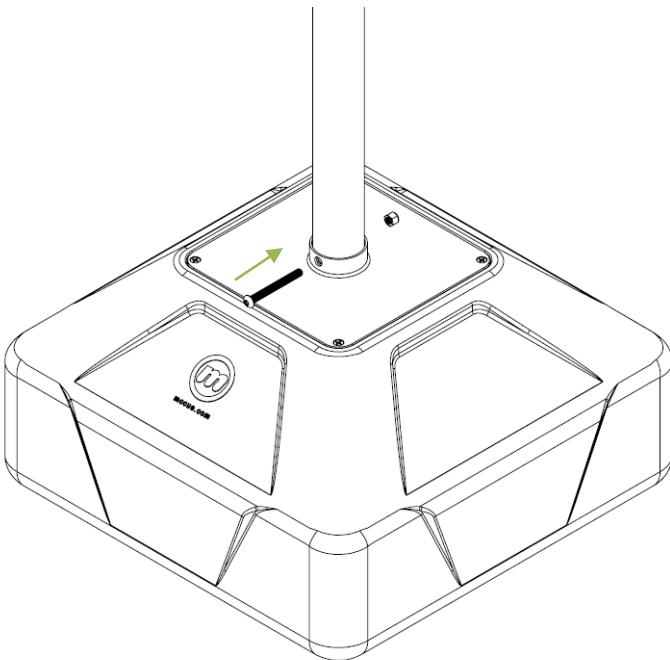

7

- Secure placards to post using the provided 3/8" bolts, nuts, and washers.

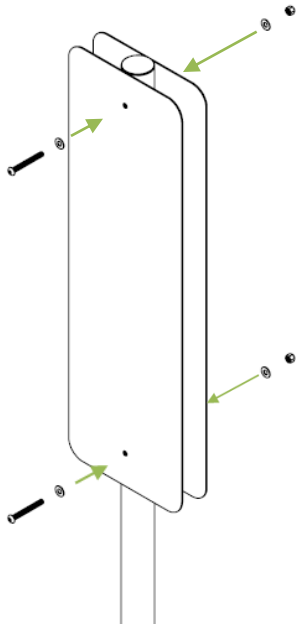

Placards not included

