

CartPark CartMagnet™ Sidewalk Unit Installation Instructions

1-cart and 2-cart wide, 8' and longer

Bill of Materials

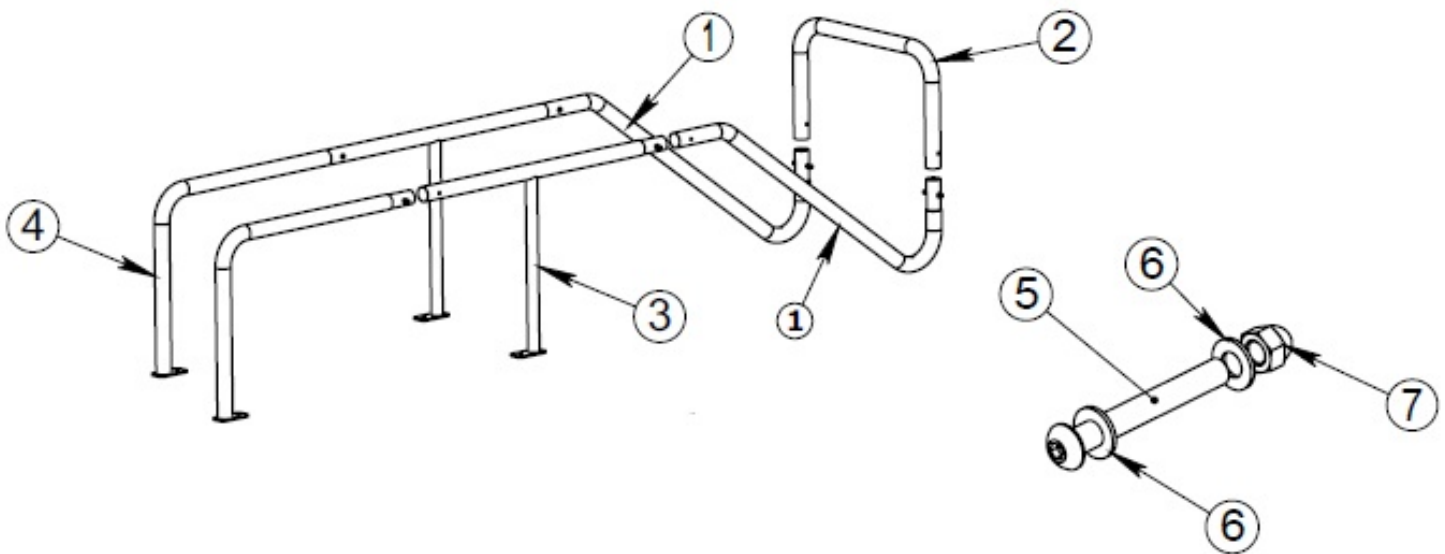

ITEM NO.	McCue Part NO.	DESCRIPTION	8' QTY.	12' QTY.	16' QTY.	20' QTY.	24' QTY.	28' QTY.	32' QTY.	36' QTY.	40' QTY.
1	CMC-SIDERAIL	SIDERAIL	2	2	2	2	2	2	2	2	2
2	CMSW-STOPBAR-1W OR CMC-STOBBAR-2W	STOPBAR, 29.0" ID OR 56.0" ID	1	1	1	1	1	1	1	1	1
3	CMSW-EXTENDER	EXTENDER	0	2	4	6	8	10	12	14	16
4	CMSW-FRONT RAIL	FRONT RAIL	2	2	2	2	2	2	2	2	2
HARDWARE											
5	3/8-16 X 3 Socket Button Head Cap Screw, Zinc		4	6	8	10	12	14	16	18	20
6	3/8-16 X 3/4" OD, Flat Washer Type A, Zinc		8	12	16	20	24	28	32	36	40
7	3/8-16 x 0.15" Thick Nylon Cap Acorn Nut, Zinc		4	6	8	10	12	14	16	18	20
ANCHORS	CS-HW-5840 LDT (5/8" x 4.0" Long)		2	4	6	8	10	12	14	16	18
ANCHORS	CS-HW-5850 LDT (5/8" x 5.0" Long)		2	2	2	2	2	2	2	2	2

Two-Person Installation Recommended

Tools Required:

- Cordless drill
- 9/16" socket bit driver or 9/16" wrench
- 7/32" hex allen key
- Leather gloves
- Tin shears
- Hammer drill
- ½" diameter carbide bit
- Pencil or marker
- 13/16" socket
- Electric impact driver
- Tape measure

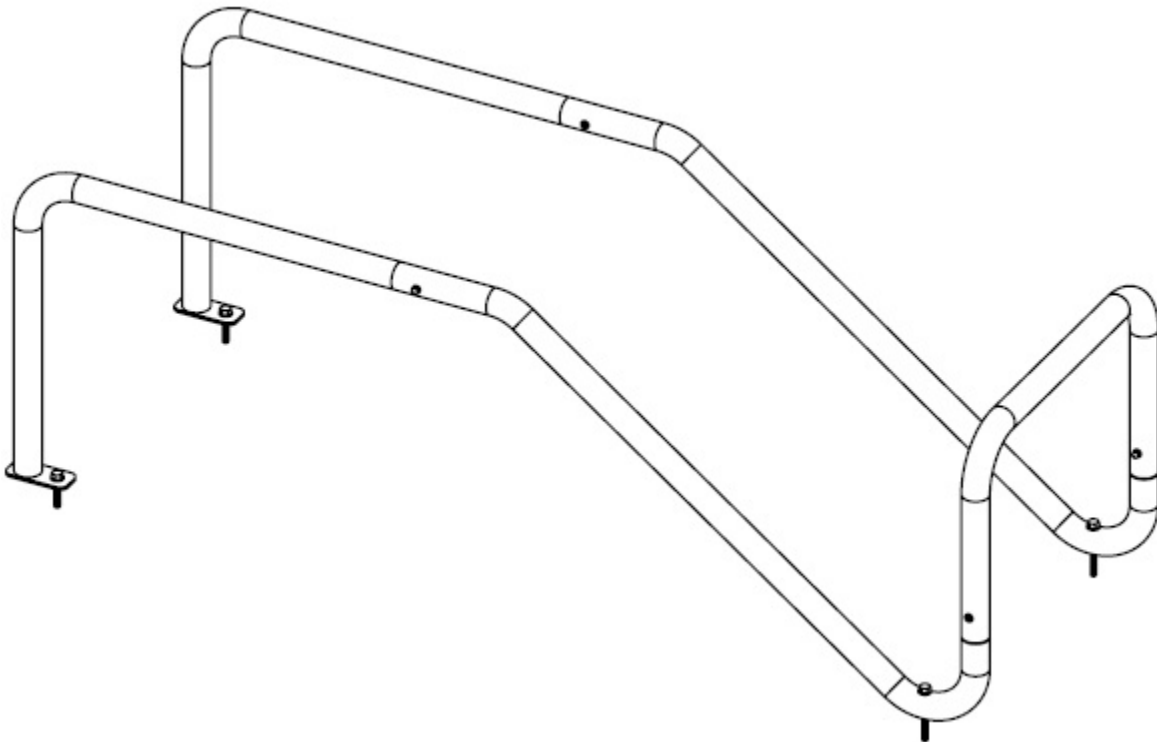

IMPORTANT: Assemble on a flat, level surface. All cart corrals should be inspected on a regular basis for damage. McCue recommends a minimum of two inspections per year in the spring and fall. Any damaged pieces, including ground frames and lane dividers which are not flat and flush with the ground, should be replaced with McCue replacement parts.

Step 1: Connect Front Rails and Siderails

Slide the front rail and siderail components together as shown to form one assembled side.

Secure the components with included hardware making sure that the acorn lock nuts are facing the outside of the unit when the sides are in the upright position.

When the first side is complete, lay it on the ground and do the same to assemble the other side.

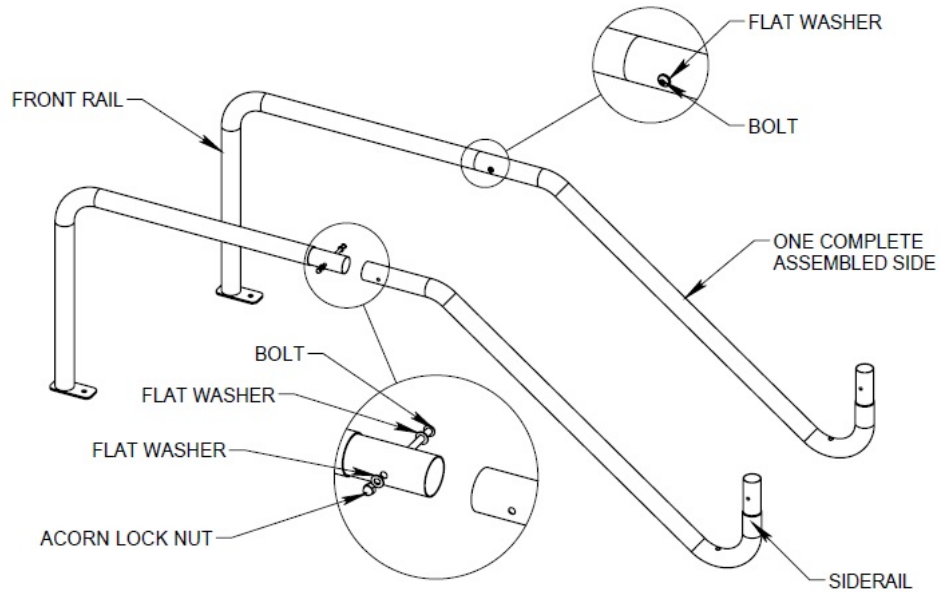

Note: For lengths greater than 8', attach extenders between the front rails and the siderails.

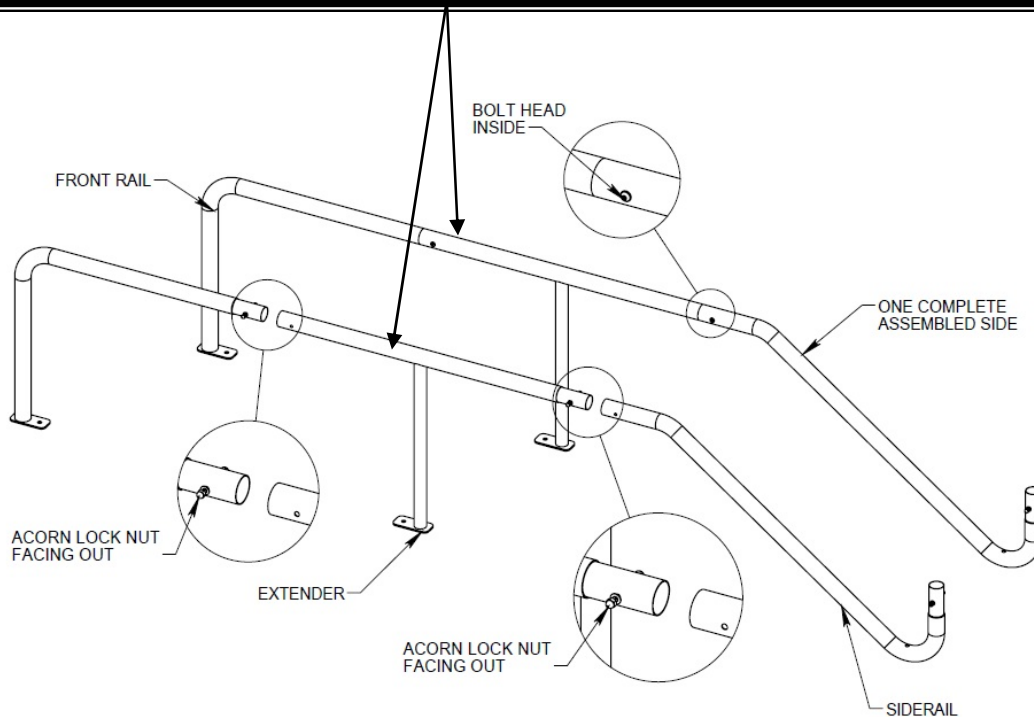

Step 2: Installing the Stopbar

Raise one completed side into the upright position and slide the back stopbar onto the rear of the siderail.

Raise the other completed side and slide the back stopbar onto the that siderail.

Note: the front end and the frame must be squared in order for the holes to align with the back stopbar.

Use the included hardware to secure the stopbar. Be sure that the acorn lock nuts are facing the inside of the unit.

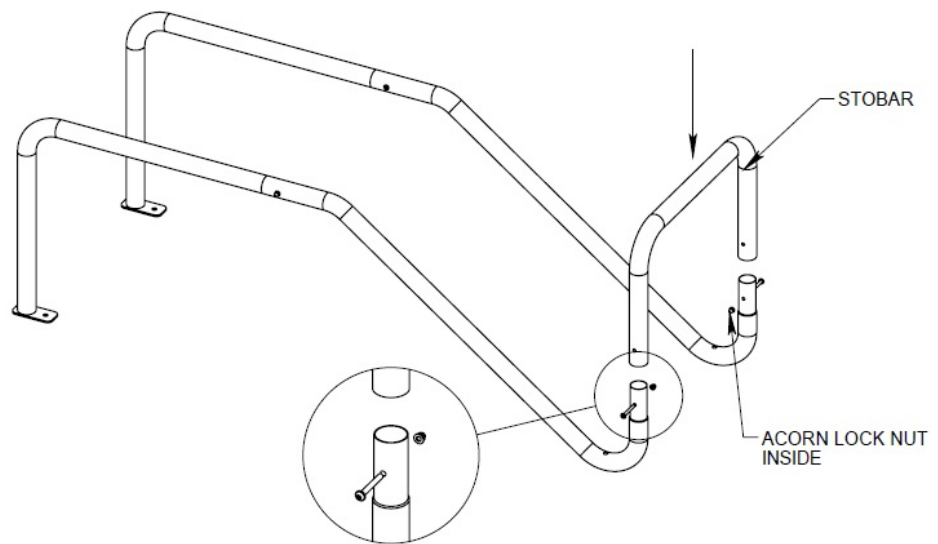

Step 3: Marking and Drilling

Place the unit in location where it will be used. Measure the width of the front end and the width of the back end to be sure that the widths are the same and the unit is squared.

Using the base plate as a template, mark all the holes with a marker or pencil.

Using a hammer drill with a 1/2" diameter carbide bit, drill holes a minimum of 1/4" deeper than the length of the anchors. The front rail and extenders will require 4" long anchors and the side rails will require 5" long anchors.

Remove dust and debris from the holes and surface.

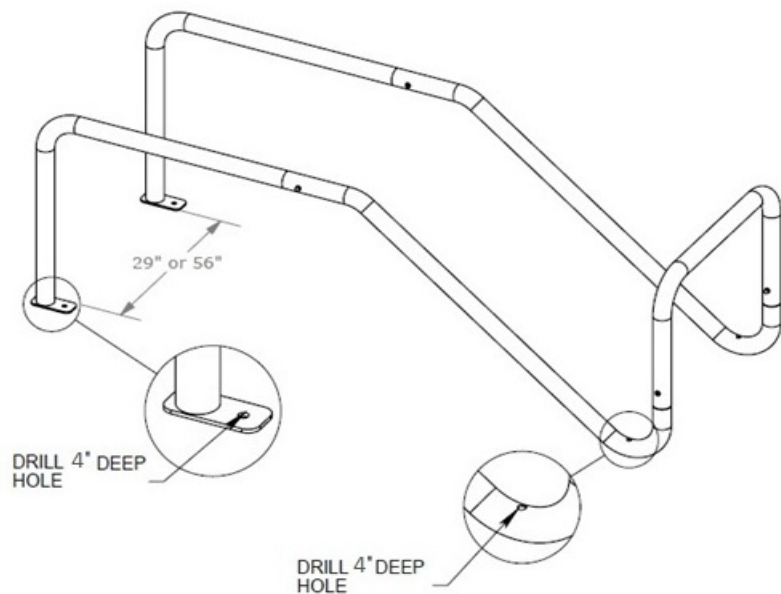

Step 4: Securing Unit to Ground

Secure the unit to the ground using the provided concrete anchor bolts.

Using an impact driver with a 13/16" socket, drive the supplied concrete anchors through the base plate and into the concrete surface.

Be sure that all anchors are partially installed before tightening them fully against the base plate.

Do not over tighten the anchors.

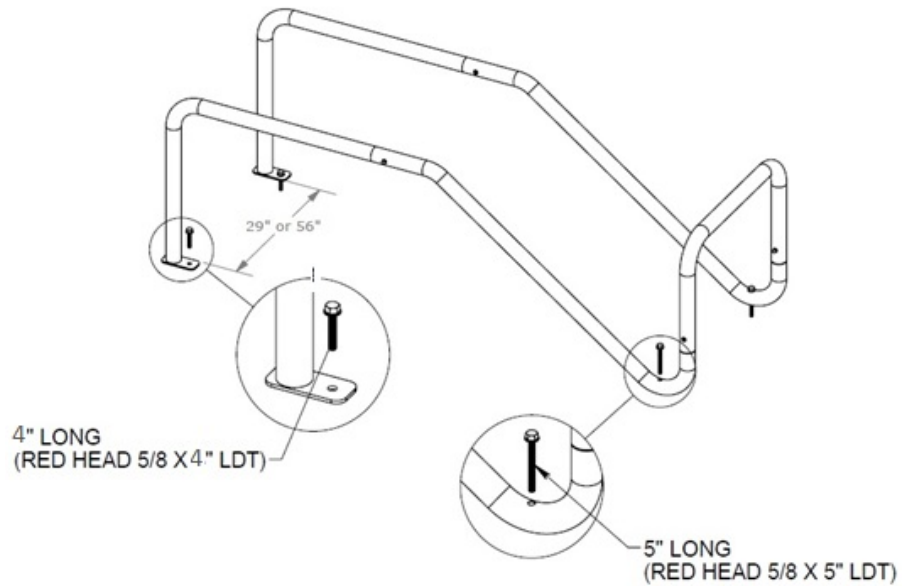

Step 5: Installation is Complete

