

CartPark Bumper Installation Instructions

CartPark Bumper Back-to-Back: BP1-BB, BP2-BB & BP3-BB

Bill of Materials

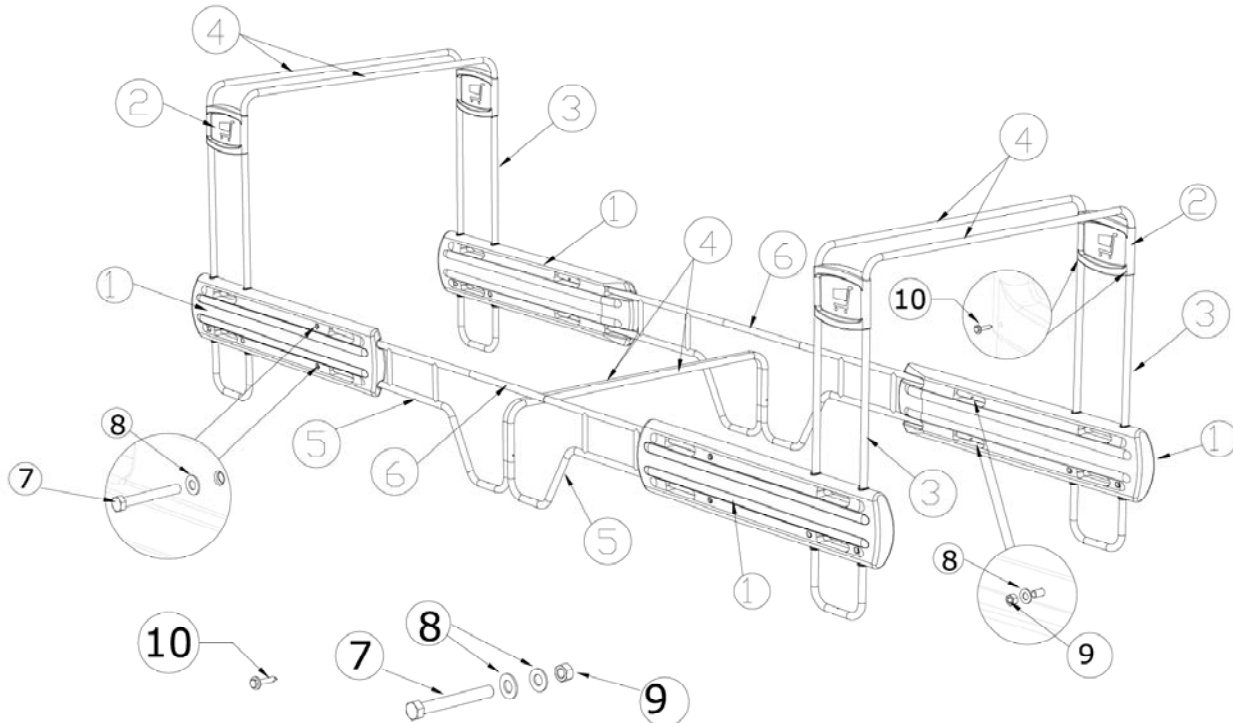

CARTPARKBUMPER 1, 2, 3 WIDTH, DOUBLE ENTRY WITH BARRIERS			
ITEM#	QTY.	DESCRIPTION	MCCUE PART NUMBER
1	4	BUMPER BARRIER	BPC-BARRIER-BM-XXX
2	4	LOGO SIGN	BPC-SIGN-BM-XXX
3	4	U-SIGN POST	BPC-USIGN POST
4	6	CROSSBAR	BPC-CROSSBAR 3 BPC-CROSSBAR 2 BPC-CROSSBAR 1
5	4	SIDERAIL	BPC-SIDERAIL
6	2	BACK TO BACK CONNECTOR	BPC-BB-CONNECT
HARDWARE KIT			
7	8	3/8-16 X 3.0" HEX BOLT, ZINC	INCLUDED
8	16	3/8" ID, FLAT WASHER, ZINC	INCLUDED
9	8	3/8-16 LOCK NUT, ZINC	INCLUDED
10	8	1/4 X 1.0" SELF-DRILLING SCREW	INCLUDED

Tools Required:

- Cordless drill
- 9/16" wrench
- 3/8" hex bit
- Leather gloves
- Tin shears

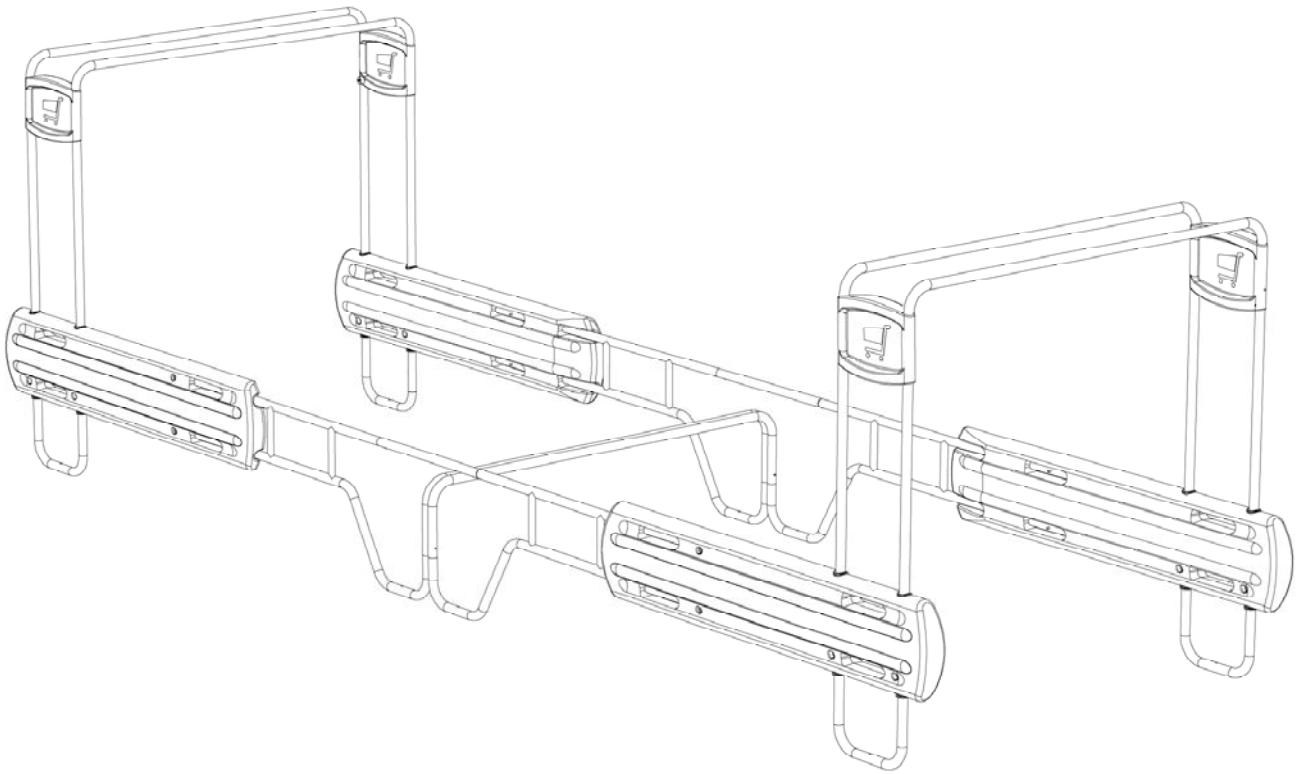

Step 1: Connecting Barriers to Posts

In the area where the unit will be used, lay out the barriers and orient them with the cutout sections of the barriers facing upward.

Slide the siderails into the barriers (A.) then slide the U-sign post into the front of the barriers (B.) Depress the pushpins to allow the U-sign post to slide completely through the hole openings. The welded washers on the U-sign posts should fit flush against the barriers at the bottom.

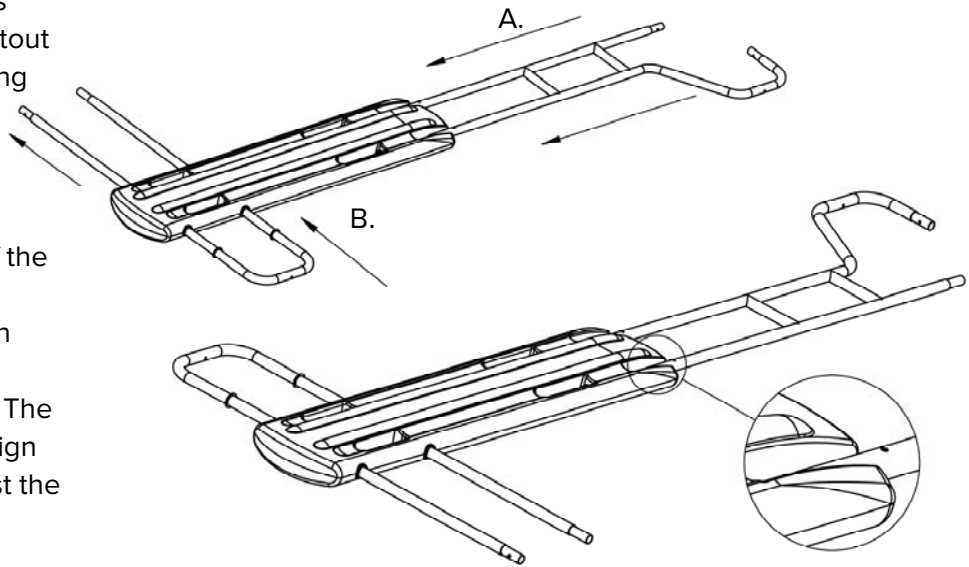

Step 2: Securing the Siderails

Lift one assembled side section into the upright position. Slide the siderails so that the in-molded holes on the barrier are aligned with the holes on the siderails.

Secure the siderails to the barrier using the provided 3/8-16x3.0 hex bolts, washers and lock nuts.

Repeat to assemble the other bumper and siderails.

Note: make sure the head of the bolt is facing the outside of the unit and the lock nut is facing inward.

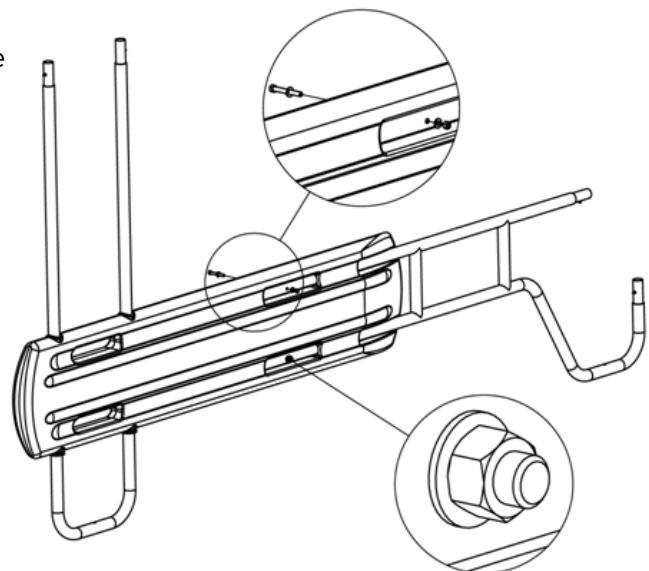
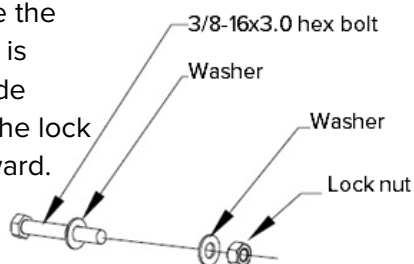

Step 3: Securing the Crossbar

Connect two of the assembled sides by sliding the crossbars into the top ends of the siderails as shown (A.) Make sure that the pushpins click into place at the bottom.

Straighten and square unit inside the parking space.

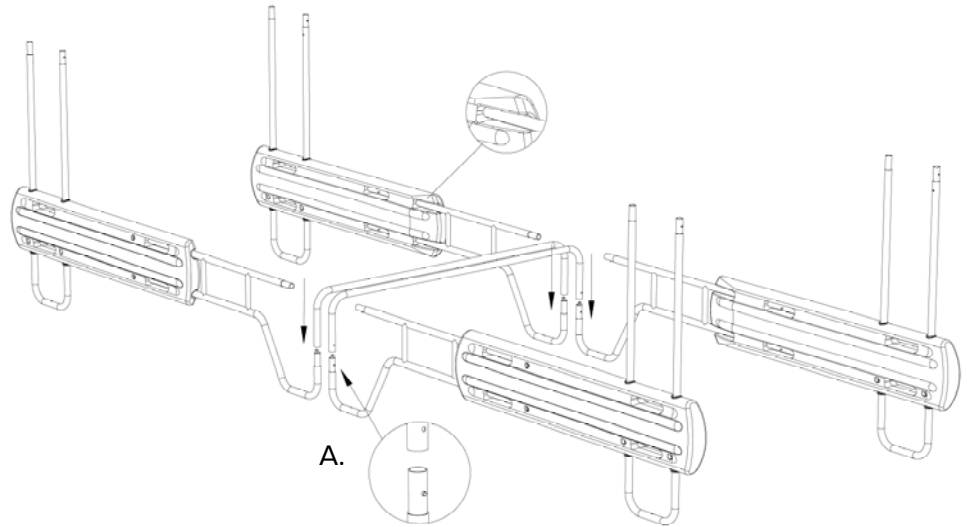

Step 4: Installing the Connectors

On one side of the unit, slide the back-to-back connector into the top end of both siderails (A.) Make sure that the pushpins click into place.

On the other side, push the siderails into the open ends of the other back-to-back connector until the pushpins click into place.

Straighten and square unit inside the parking space.

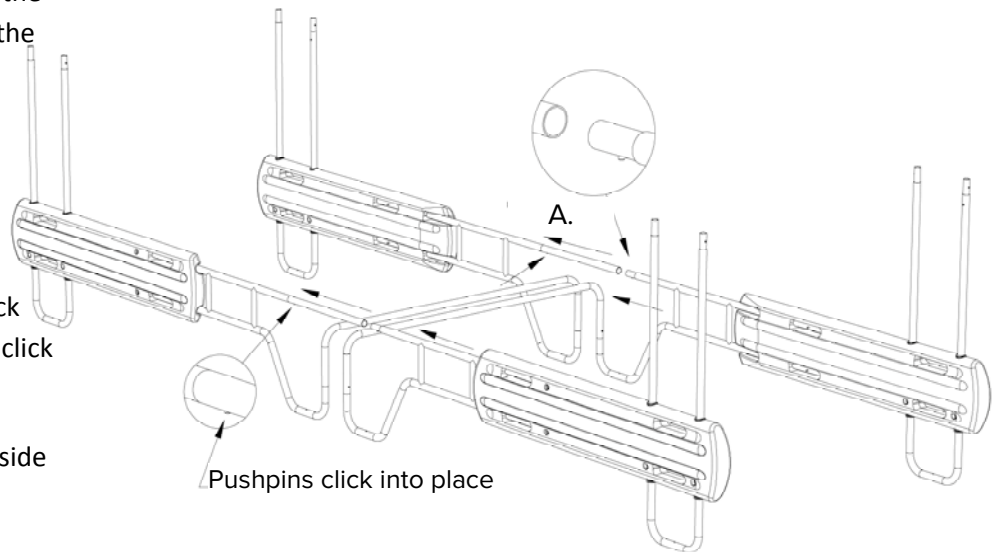

Step 5: Installing the Crossbars

Slide signs onto U-sign posts (A.); you will need to depress the pushpins to allow the signs to slide through.

Slide one top lock crossbar on top of the U-sign post (B.), depressing the pushpins to allow the connection to lock into place.

Repeat this step to install the three remaining top lock crossbars.

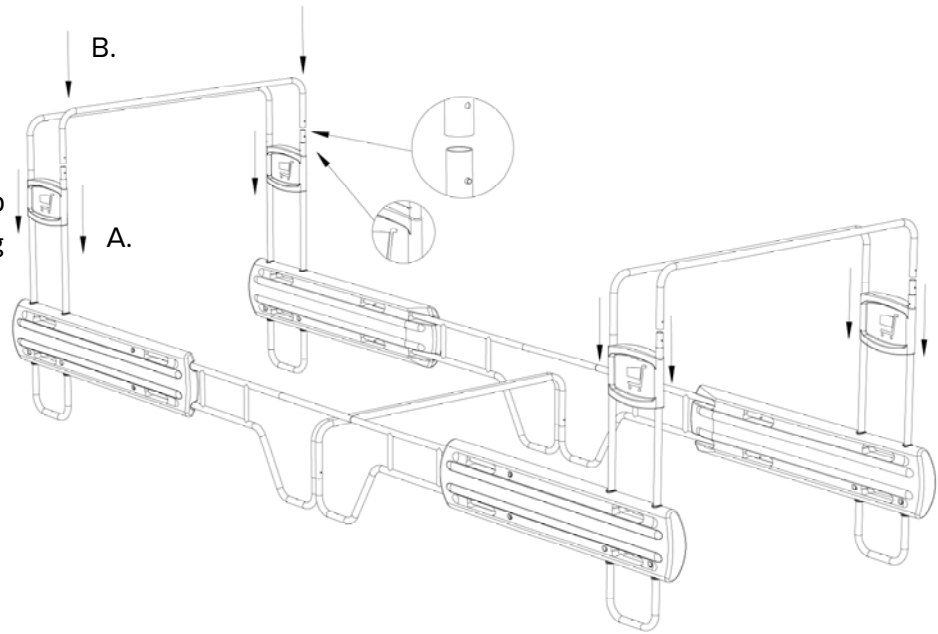

Step 6: Securing the Signs

Slide the sign upward past the post connection until the predrilled holes in the sign are aligned with the predrilled holes in the U-sign posts.

Secure the signs to the posts using two (2) $\frac{1}{4}$ x 1.0" self-drilling screws per sign.

Note: the bottom of the sign should measure 75" from the ground when the sign is in place.

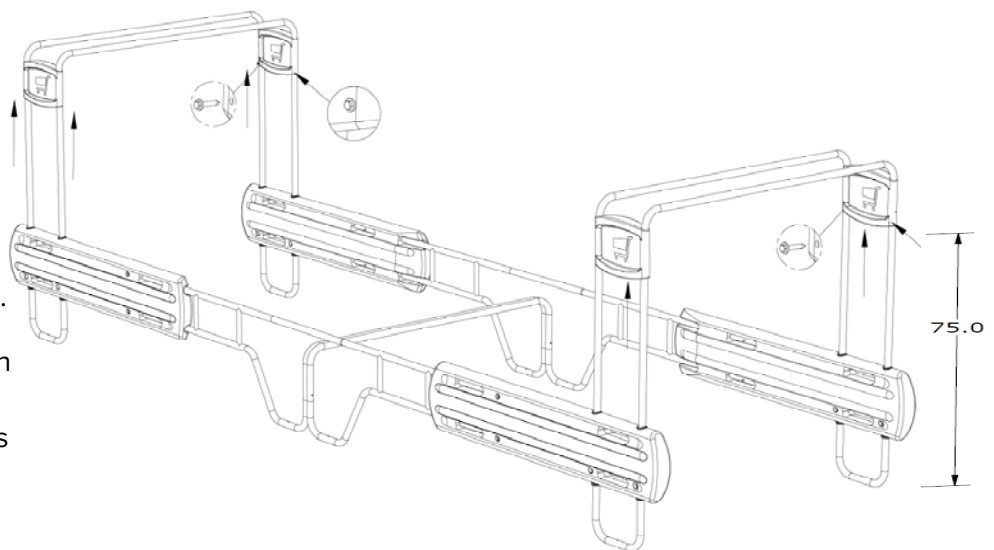

Step 7: Installation is Complete

