

CartPark Bumper

Installation Instructions

CartPark Bumper BP1, BP2, BP3 Single Entry Open Unit

Bill of Materials

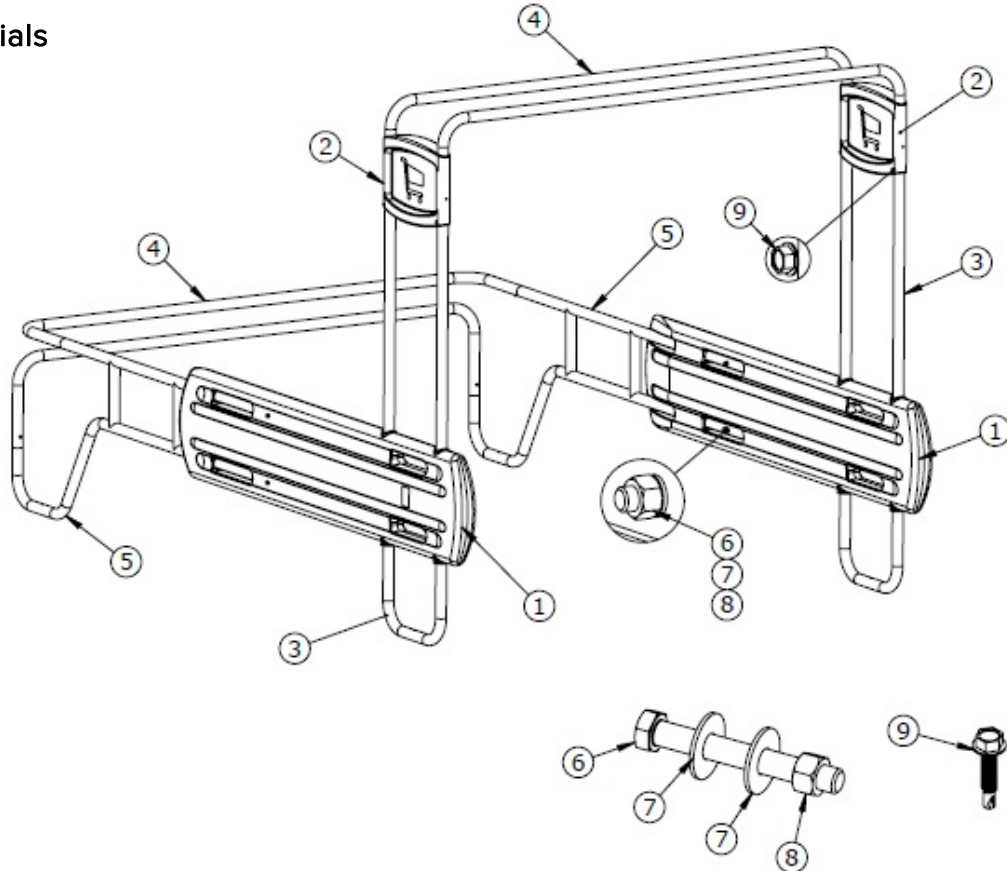

CARTPARK BUMER SINGLE ENTRY (BP1-BP2-BP3-COLOR)			McCUE PART NUMBER
ITEM#	QTY.	DESCRIPTION	
1	2	BUMPER BARRIER	BPC-BARRIER-BM-XXX
2	2	LOGO SIGN	BPC-SIGN-BM-XXX
3	2	U-SIGN POST	BPC-USIGN-POST
4	4		BPC-CROSSBAR3
		CROSSBAR	BPC-CROSSBAR2
			BPC-CROSSBAR1
5	2	SIDERAIL	BPC-SIDERAIL
HARDWARE KIT			
6	4	3/8-16 x 3.0" Hex Head Bolt, Zinc	INCLUDED
7	8	3/8" ID, Flat Washer, Zinc	INCLUDED
8	4	3/8-16 Nylon Lock Nuts, Zinc	INCLUDED
9	4	1/4 x 1.0" Long Self-drilling Screw "TEK"	INCLUDED

Tools Required:

- Cordless drill
- 9/16" wrench
- 3/8" hex bit
- Leather gloves
- Tin Shears

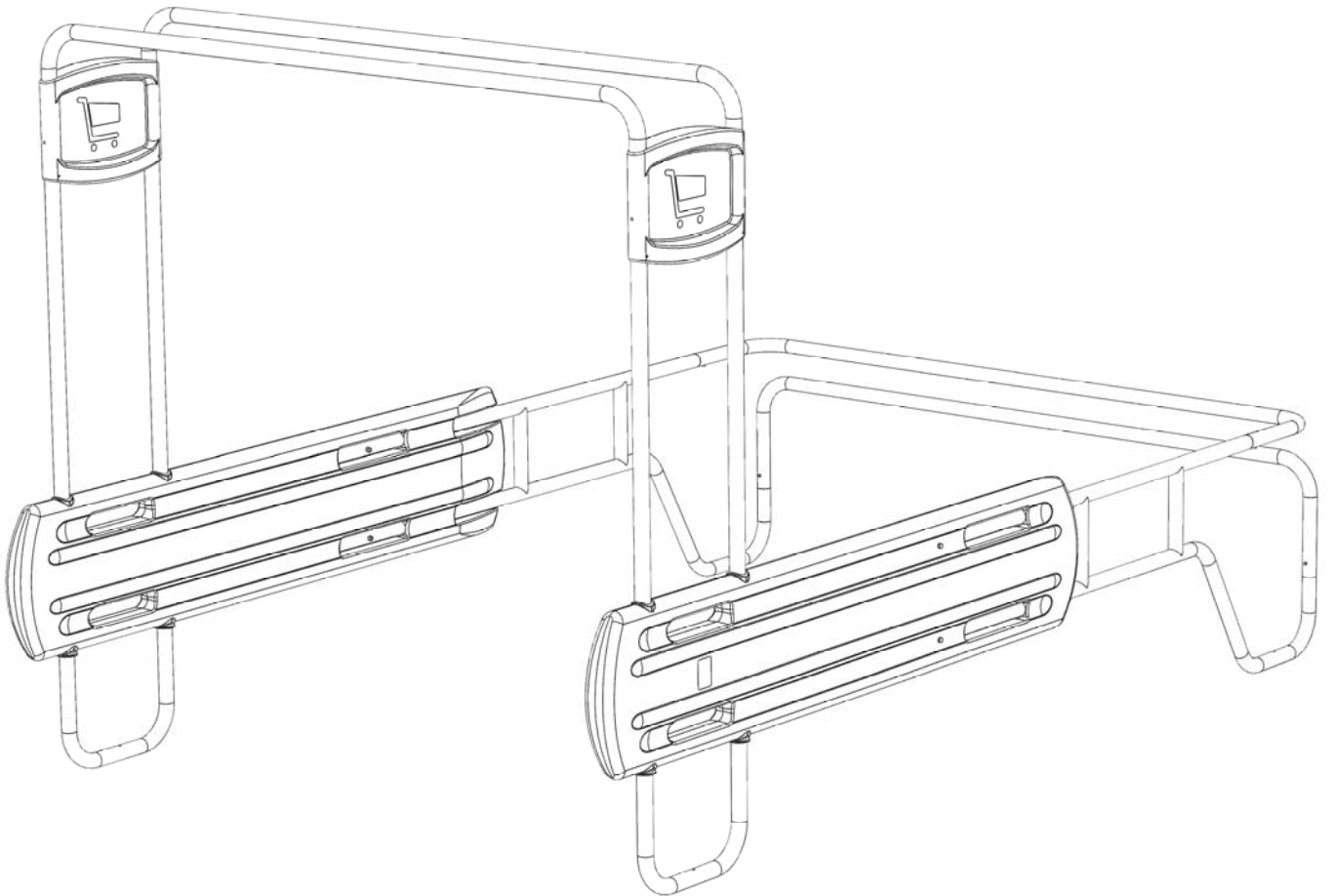

Step 1: Connecting Barriers to Posts

In the area where the unit will be used, lay out the barriers and orient them with the cutout sections of the barriers facing upward.

Slide the siderails into the barriers (A.) then slide the U-sign post into the front of the barriers (B.) Depress the pushpins to allow the U-sign post to slide completely through the hole openings. The welded washers on the U-sign posts should fit flush against the barriers at the bottom.

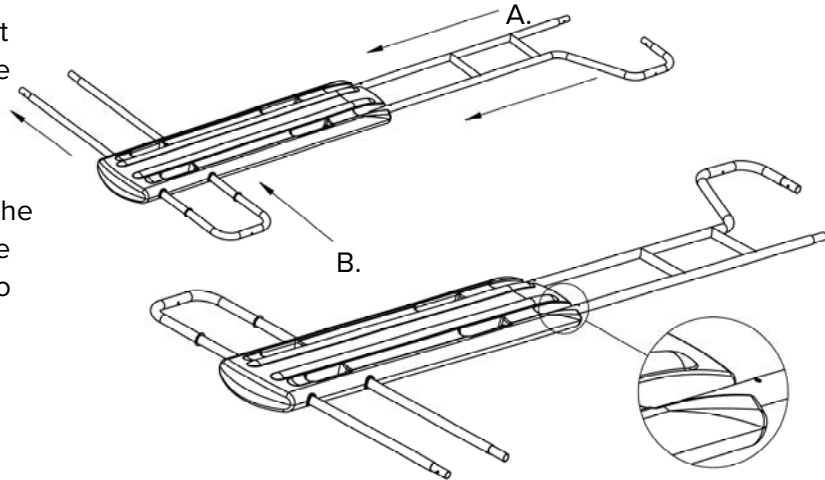

Step 2: Securing the Siderails

Lift one assembled side section into the upright position. Slide the siderails so that the in-molded holes on the barrier are aligned with the holes on the siderails.

Secure the siderails to the barrier using the provided 3/8-16x3.0 hex bolts, washers and lock nuts.

Repeat to assemble the other bumper and siderails.

Note: make sure the head of the bolt is facing the outside of the unit and the lock nut is facing inward.

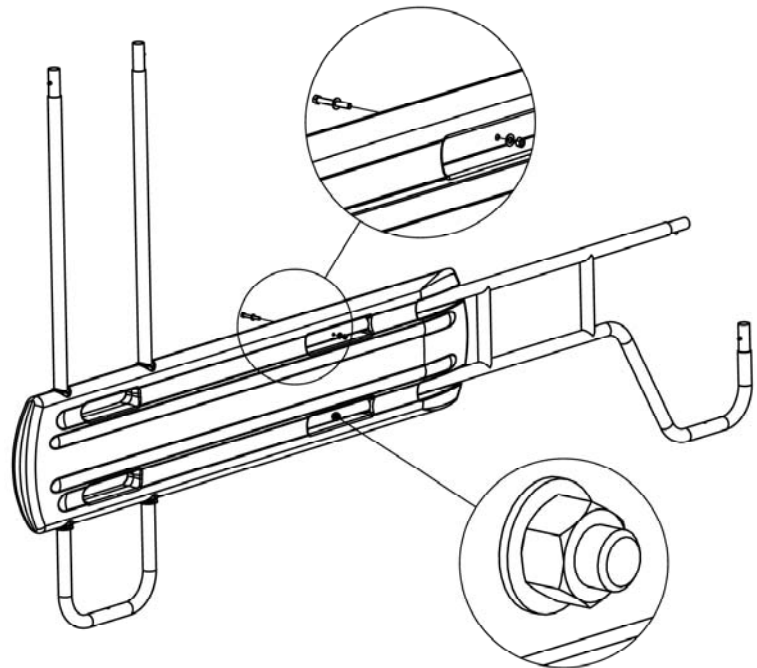
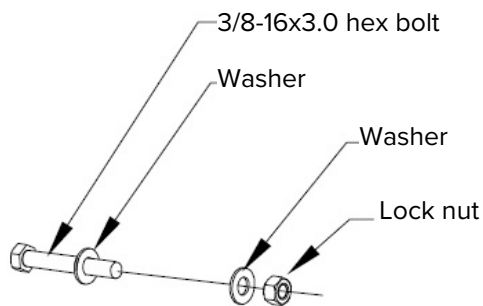

Step 3: Securing the Crossbar

Slide the crossbar into the top ends of the siderails as shown (A.) Make sure that the pushpins click into place at the bottom.

Straighten and square unit inside the parking space.

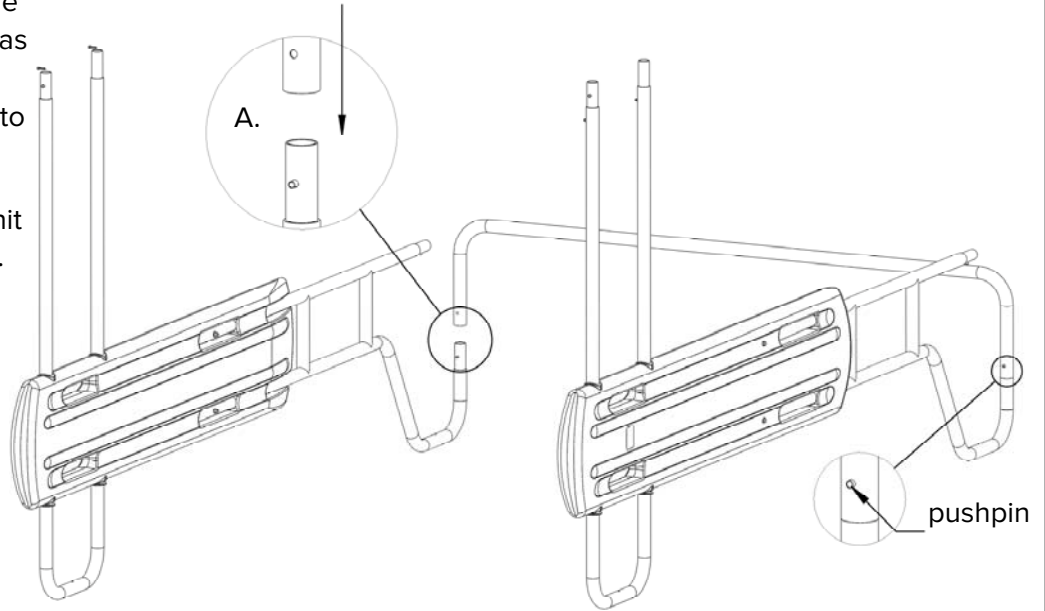

Step 4: Installing the Rear Crossbar

Slide the crossbar into the top bar of the siderail (A.) Make sure that the pushpins click into place.

Do the same on the other side, (B.) making sure that the pushpins click into place.

Straighten and square unit inside the parking space.

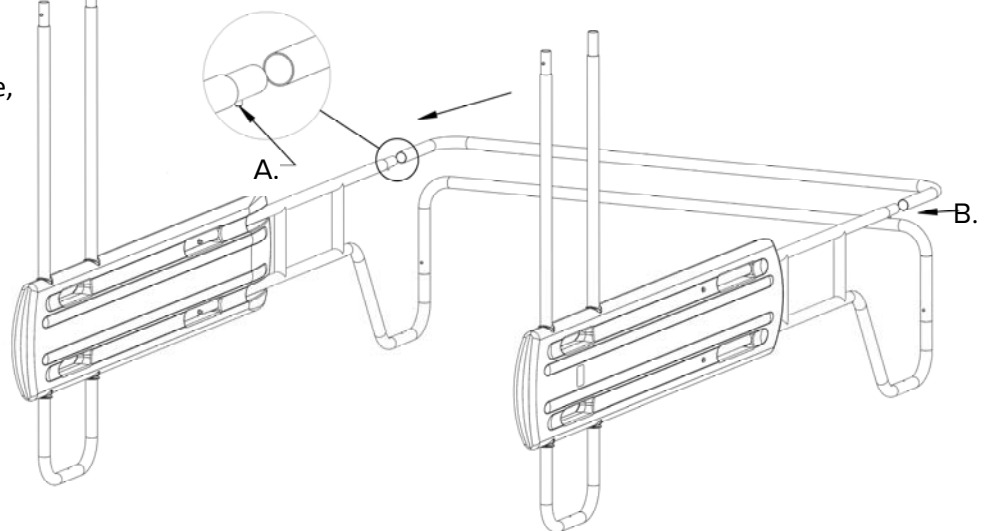

Step 5: Installing the Top Crossbars

Slide signs onto U-sign posts (A.); you will need to depress the pushpins to allow the signs to slide through.

Slide one top lock crossbar on top of the U-sign post (B.), depressing the pushpins to allow the connection to lock into place.

Repeat to install the other top lock crossbar (C.).

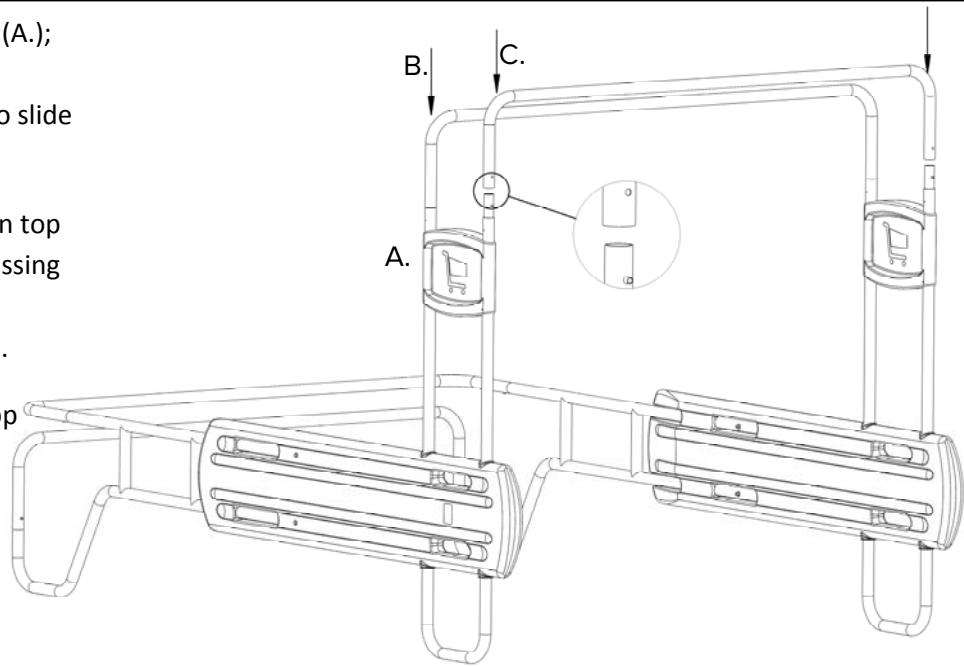

Step 6: Securing the Signs

Slide the sign upward past the post connection until the predrilled holes in the sign are aligned with the predrilled holes in the U-sign posts.

Secure the signs to the posts using two (2) $\frac{1}{4}$ x 1.0" self-drilling screws per sign.

Note: the bottom of the sign should measure 75" from the ground when the sign is in place.

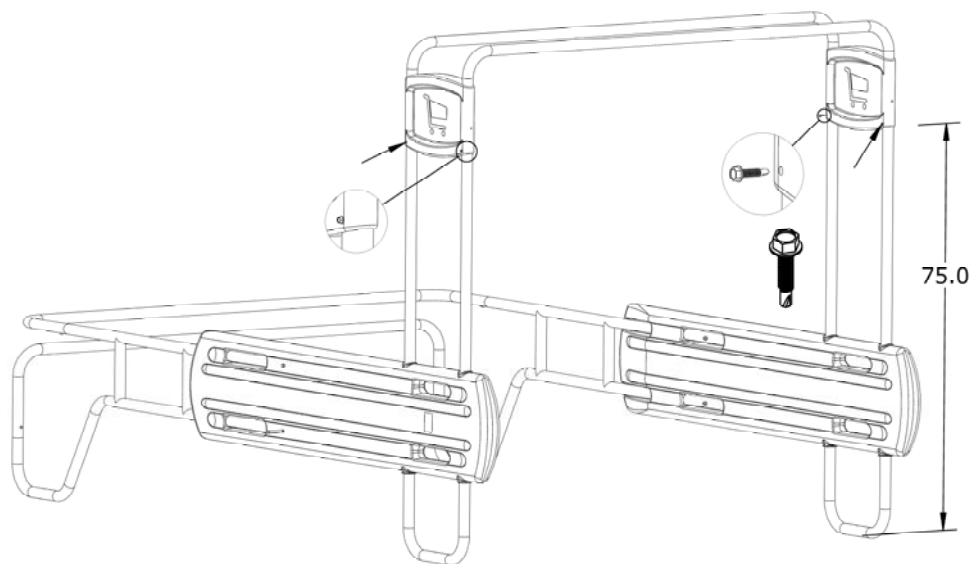

Step 7: Installation is Complete

