

CartPark Covered Peaked 8-Barrier Installation Instructions

Bill of Materials

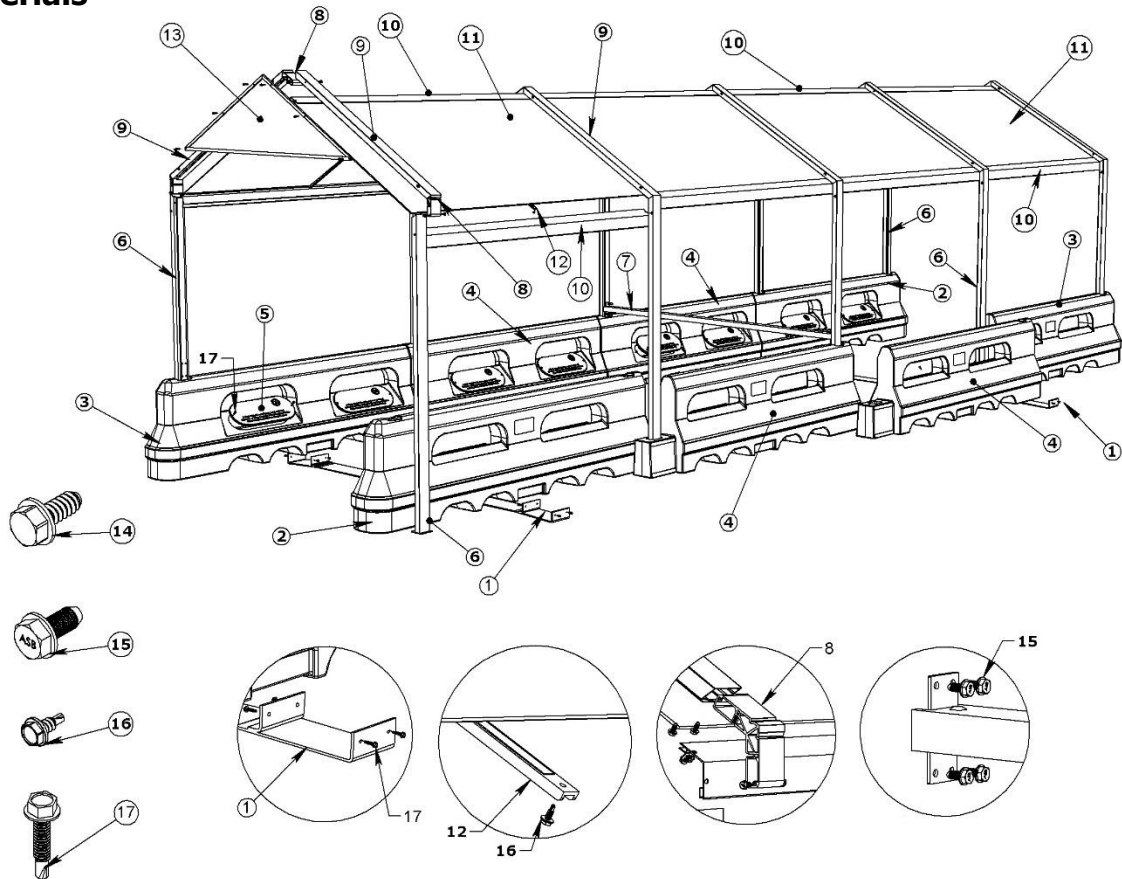

CARTPARKCOVERED PEAKED 8 BARRIERS (SSC8B-###) 2018			
ITEM NO.	QTY.	DESCRIPTION	MCCUEPART #'S
1	2	GROUND FRAME 1/4" THICK PLATE	CPC-C-GF
2	2	FEMALE PLASTIC ROTO-MOLDED BARRIERS	CBPC-BARRIER-B-###
3	2	MALE PLASTIC ROTO-MOLDED BARRIERS	CBPC-BARRIER-A-###
4	4	MIDDLE PLASTIC ROTO-MOLDED BARRIERS	CBPC-BARRIER-MID-###
5	16	OBLONG PLASTIC CAP 20" X 6.0" WIDE	CBPC2-BARRIERFILLCAP-###
6	10	POST WITH WELDED FOOT PLATE, 72.75" LONG	CPC-C-POST-FAB
7	1	STOPBAR ASSEMBLY, 90.41" LONG, USE TYPE F SCREWS	CPC-C-STOPBAR-ASM
8	15	EXTRUSION CORNER BRACKET, 2.862" LONG	CPC-C-BRACK-FAB
9	10	TRUSS FRAME SUPPORT, 53.91" LOGN MITER BOTH SIDES	CPC-C-TRUSS-FAB
10	12	ROOF SUPPORT CHANNEL FABRICATION, 78.29" LONG	SSC-R-SUPORT-CHNL
11	8	UV ROOF PANEL SHEET, 79.75" X 48" X 1/4" THICK	CPC-C-ROOFPANEL
12	8	ROOF PANEL STIFFENER SUPPORT, 48"X3/4"X0.35"	CPC-C-R-STIFF-FAB
13	2	TRIGLASS PLASTIC PANEL ASSEMBLY, 62.78"X18.89X1/2"	CPC-C-TRIGLASS-ASM
HARDWARE			
14	120	S/S UNSLOTTED HEX HEAD 5/16-12X3/4 SCREWS "B"	CPC-8B-HARDWARE
15	8	S/S HEX HEAD 5/16-18X3/4 SELF TAPPING "F" SCREWS	
16	16	S/S HEX HEAD #10X1/2 SELF DRILLING SCREWS	
17	60	S/S HEX HEAD #14X1.25 SELF DRILLING SCREWS	

Two-Person Installation

Tools Required:

- Leather work gloves
- (2) Six foot Step ladders
- Tape Measure
- Cordless Drill with torque setting & back-up batteries
- 5/16" Hex head driver Bit
- 3/8" Hex Head Driver Bit
- 1/2" Hex head driver Bit
- Brush & Dust Pan
- Utility Knife
- Cloth Cleaning Rags
- Tin Shears
- 2400 lbs. of sand, pea stone or gravel for ballasting.

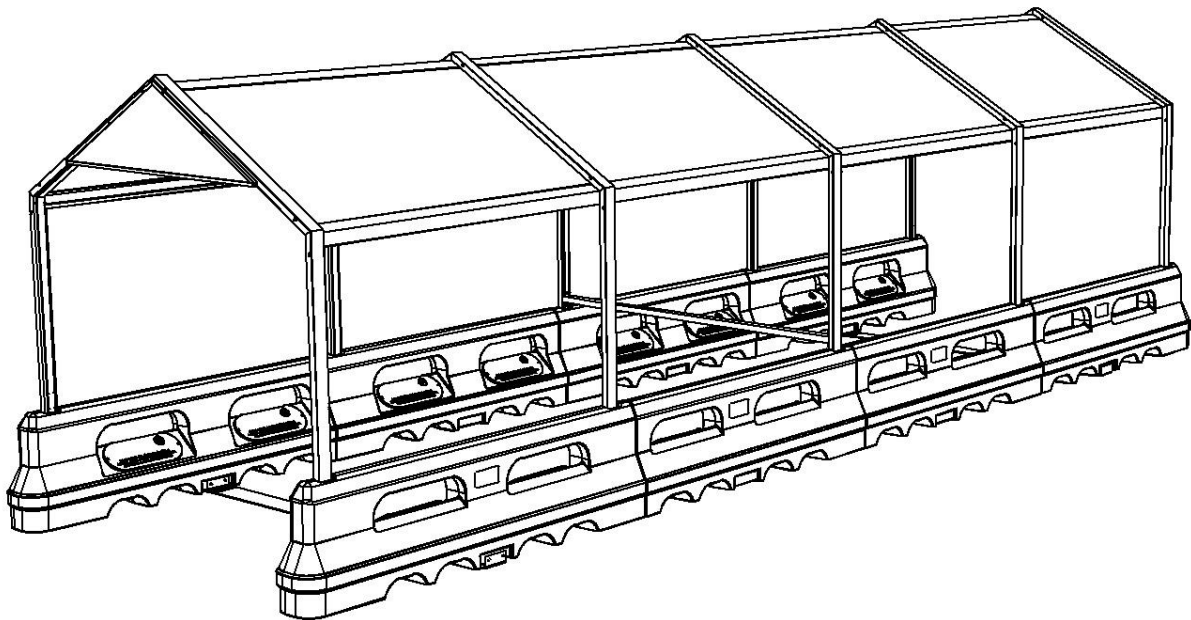

IMPORTANT: Assemble on a flat, level surface. All cart corrals should be inspected on a regular basis for damage. McCue recommends a minimum of two inspections per year in the spring and fall. Any damaged pieces, including ground frames and lane dividers which are not flat and flush with the ground, should be replaced with McCue replacement parts.

Step 1: Layout

Set the barriers and each ground frame on the ground in the location where the cart corral will be used (as shown below). Slide the barriers together at the interlocking ends. Be sure that the filler holes, located on the side of each barrier, are facing inward. Place a ground frame across each entrance point of the unit.

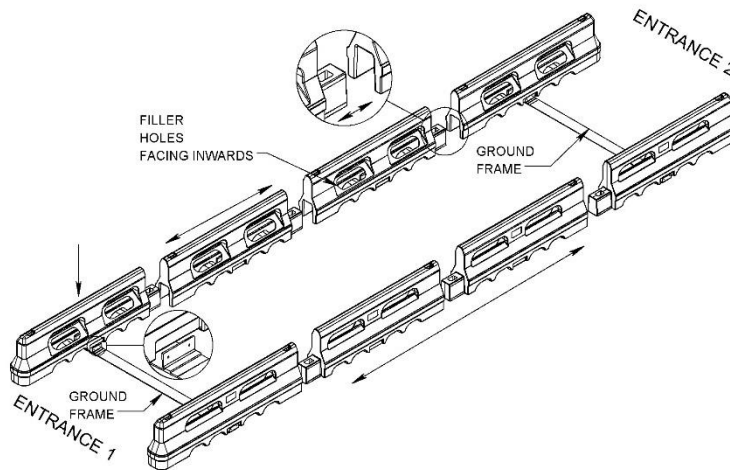

Step 2: Post Placement

Insert the posts with welded footplates into the holes of the barriers making sure that the angle cut on the posts is facing the inside of the unit and the footplates are positioned at the bottom of the barriers when barriers and posts are placed in the upright position. Stand barriers and posts upright.

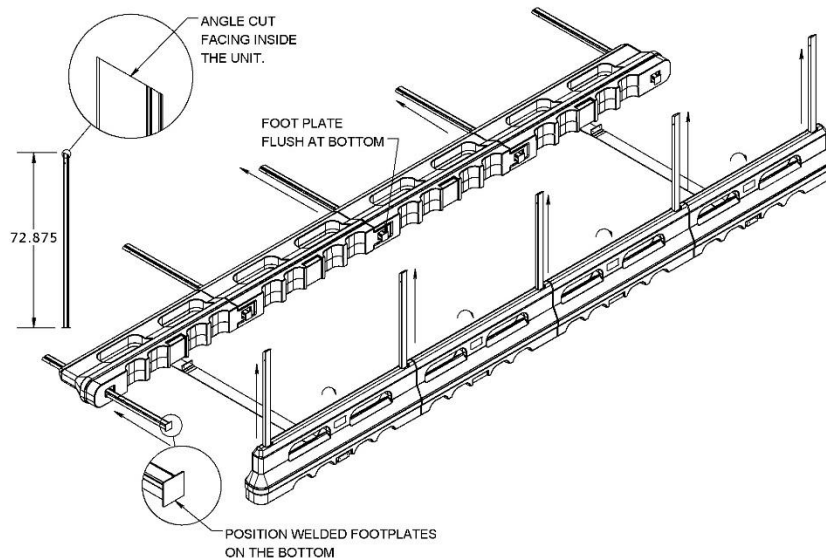

Step 3: Secure Ground Frame and Stop Bar

Slide the Stop Bar into the two middle posts so that it connects at the base of each post and top of the barriers. Align the holes and secure the bar to each post with four (4) 5/16-18x3/4" self-tapping screws on each side.

Secure the Ground Frame to the barriers using eight (8) 14x1.25" self-drilling screws.

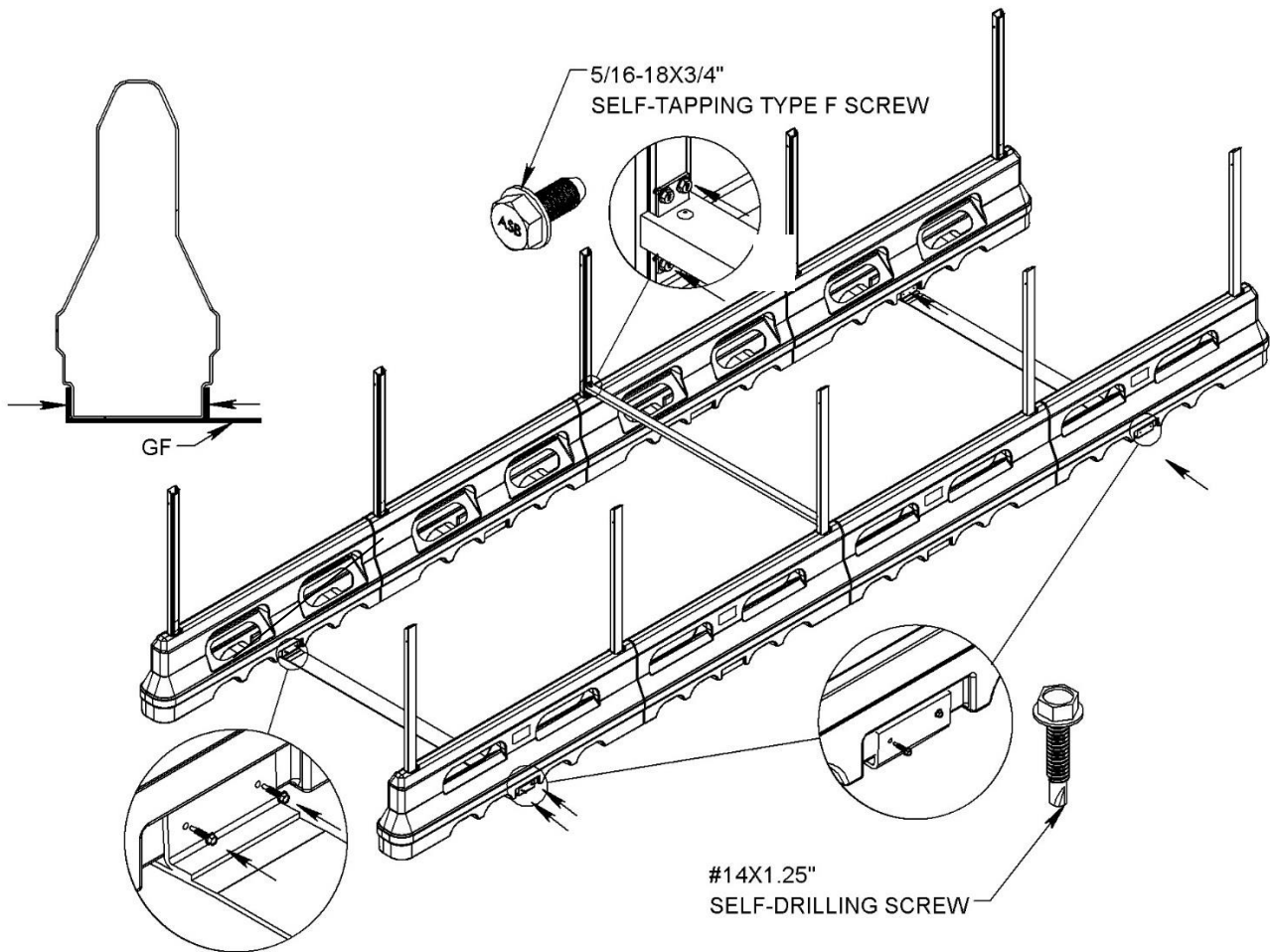

Step 5: Securing Top Roof Support Channels

Make sure the unit is squared diagonally before continuing.

Slide the roof support channels (#10) in between each truss as shown below. Align the predrilled holes on the roof supports with the truss assemblies. Secure the roof support channels with four (4) 5/16-12x3/4" type F hex head self-tapping screws (#14).

Note: Make sure that the aluminum roof supports sit flush with the inner angle of the trusses. Do not over-torque the screws.

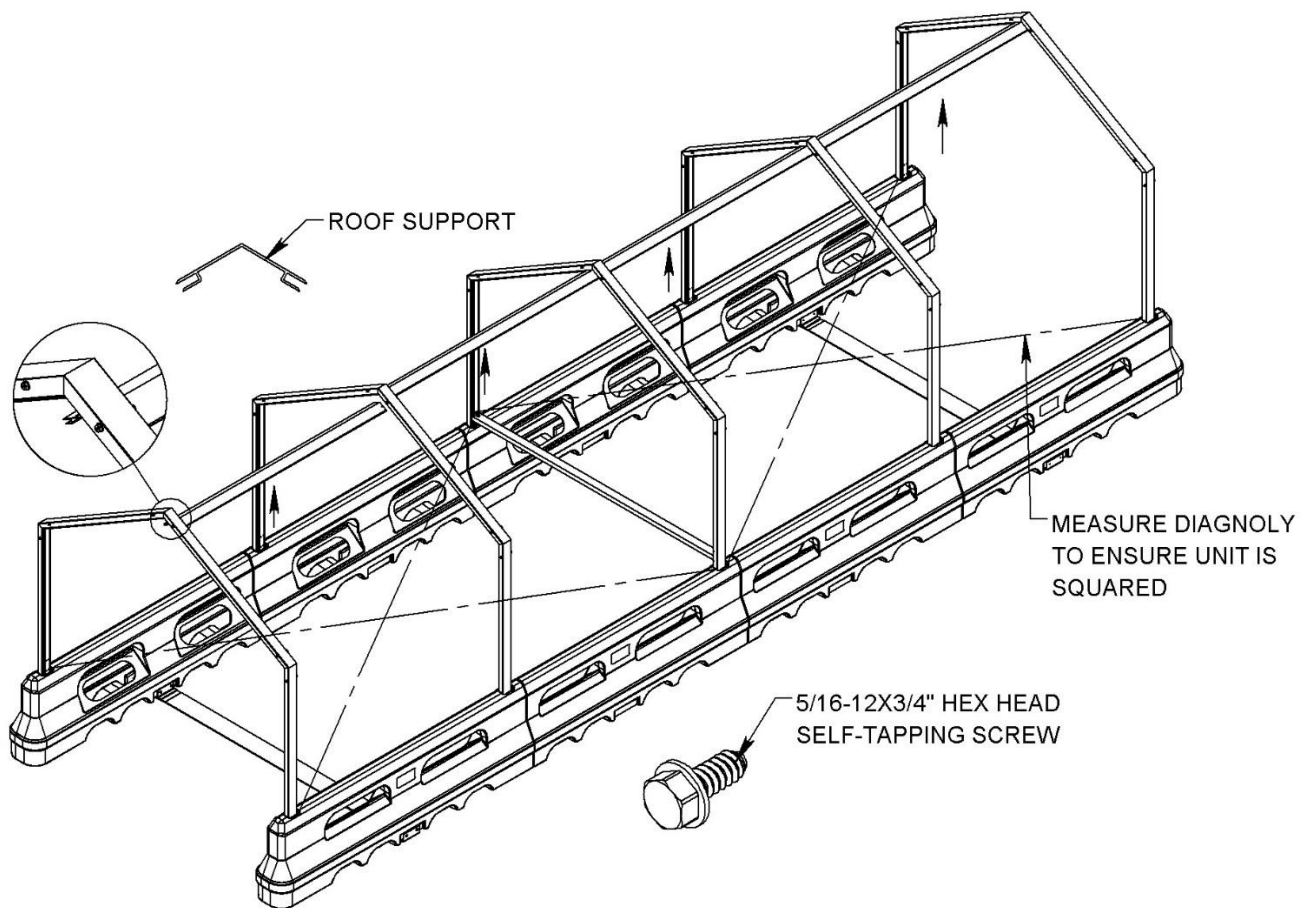

Step 6: Installing the Roof Panels

Each roof panel has protective film on it with instructions for proper placement of UV side. Note the appropriate placement of the panel then remove the protective film.

From inside the unit, with two people holding a roof panel, slide one side of the roof panel into the groove of one side of the truss (Figure A). Note: It is easiest to start at the top corner. Then flex the middle of the panel slightly to align and insert it into the other side of the truss. Slowly guide the roof panel into place.

Once situated in both sides of the trusses, slide the top portion of the roof panel into the recessed area of the roof support channel as shown in Figure B.

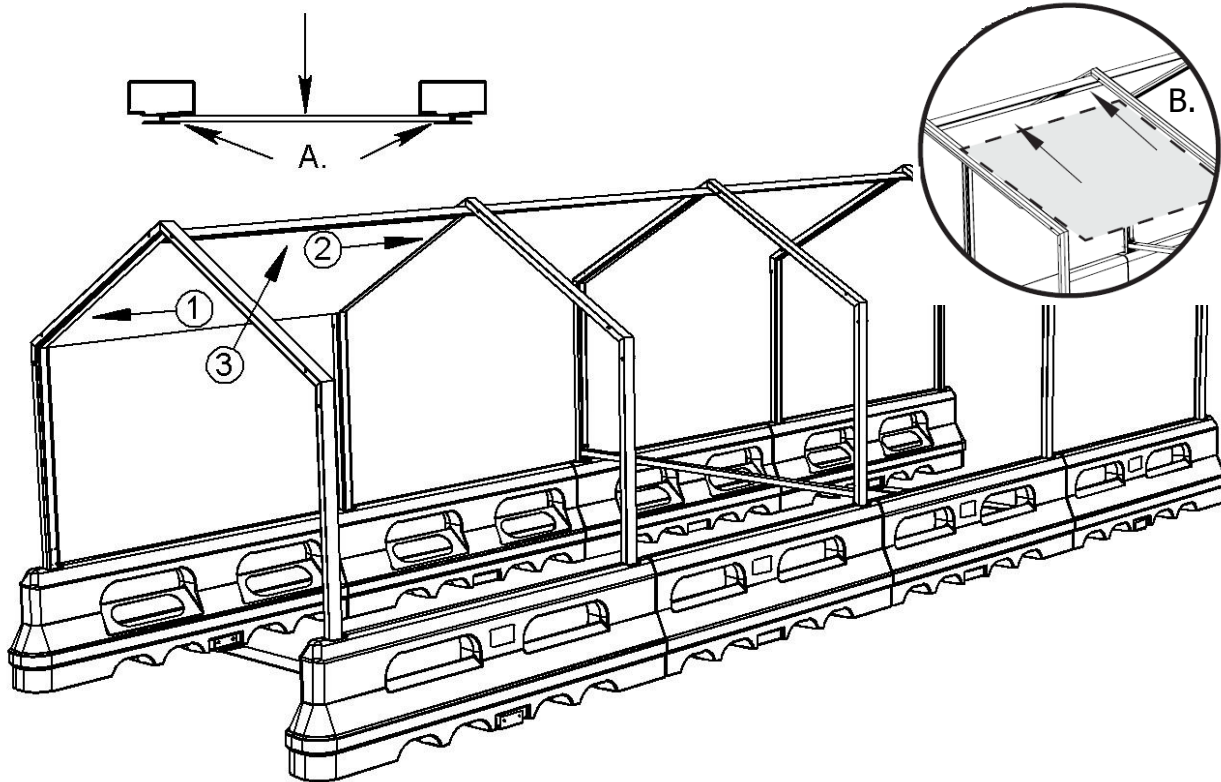

Step 7: Securing Side Roof Panels

Measure between the uprights to ensure that each measures 80" from center to center.

From the inside of the unit, slide the roof support channel between the trusses and into the bottom edge of the roof panel as shown below.

Make sure that the roof support channel sits flush with the trusses and that all predrilled holes line up.

Secure the roof support channel with type F hex head self-tapping screws. Repeat this step for all remaining roof panels.

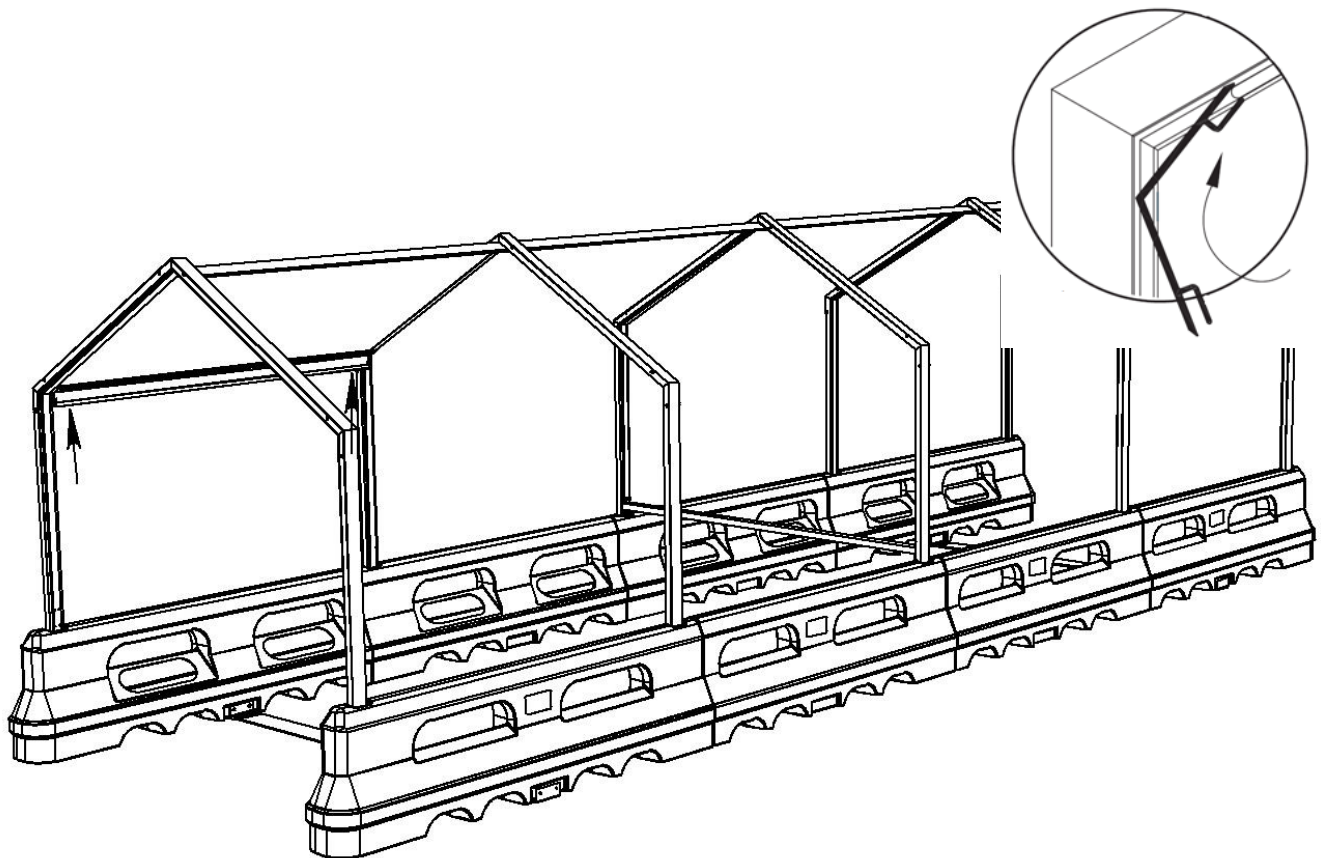

Step 8: Installing Stiffeners

Make sure the roof panels are clean and dry prior to installing the stiffening bars.

Peel off the protective paper from the double-sided tape on a roof panel stiffener (#12). Align the holes in the roof panel stiffener with those on the top and lower roof support channels and secure with two (2) 10x1/2" hex head self-drilling screws.

Once secure, press the roof sheets into the roof panel stiffeners to adhere.

Repeat for the remaining roof panel stiffeners.

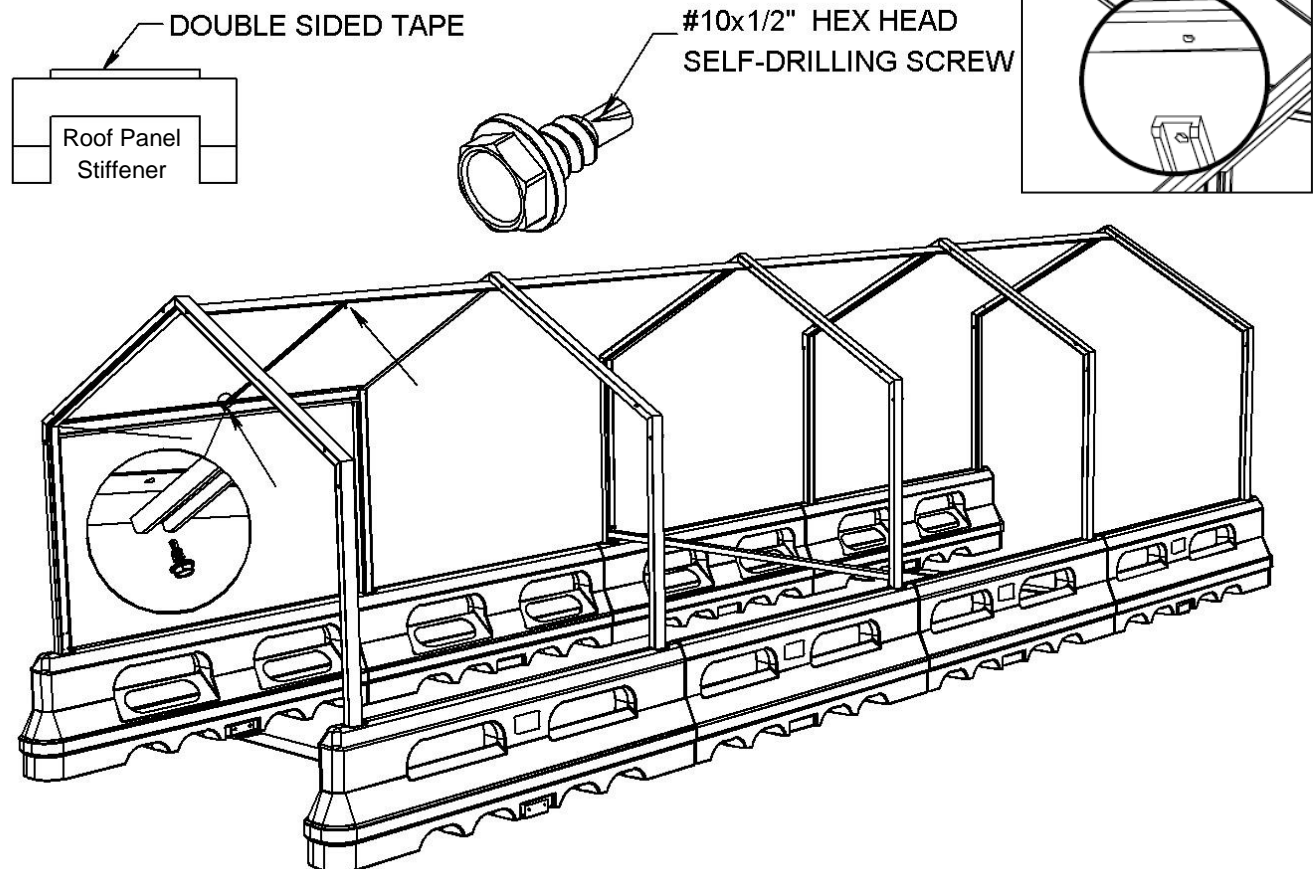

Step 9: Installing Triglass Panels

Peel off the protective film from the triglass panel Assembly. Locate on the front face of the unit.

With the triglass panel assembly aligned to truss and the bottom rail horizontal to ground.

Secure the triglass assembly into the truss with six (6) 14X1.25" self-drilling screws. Do not over-tighten screws.

Repeat this process at the other end of the unit.

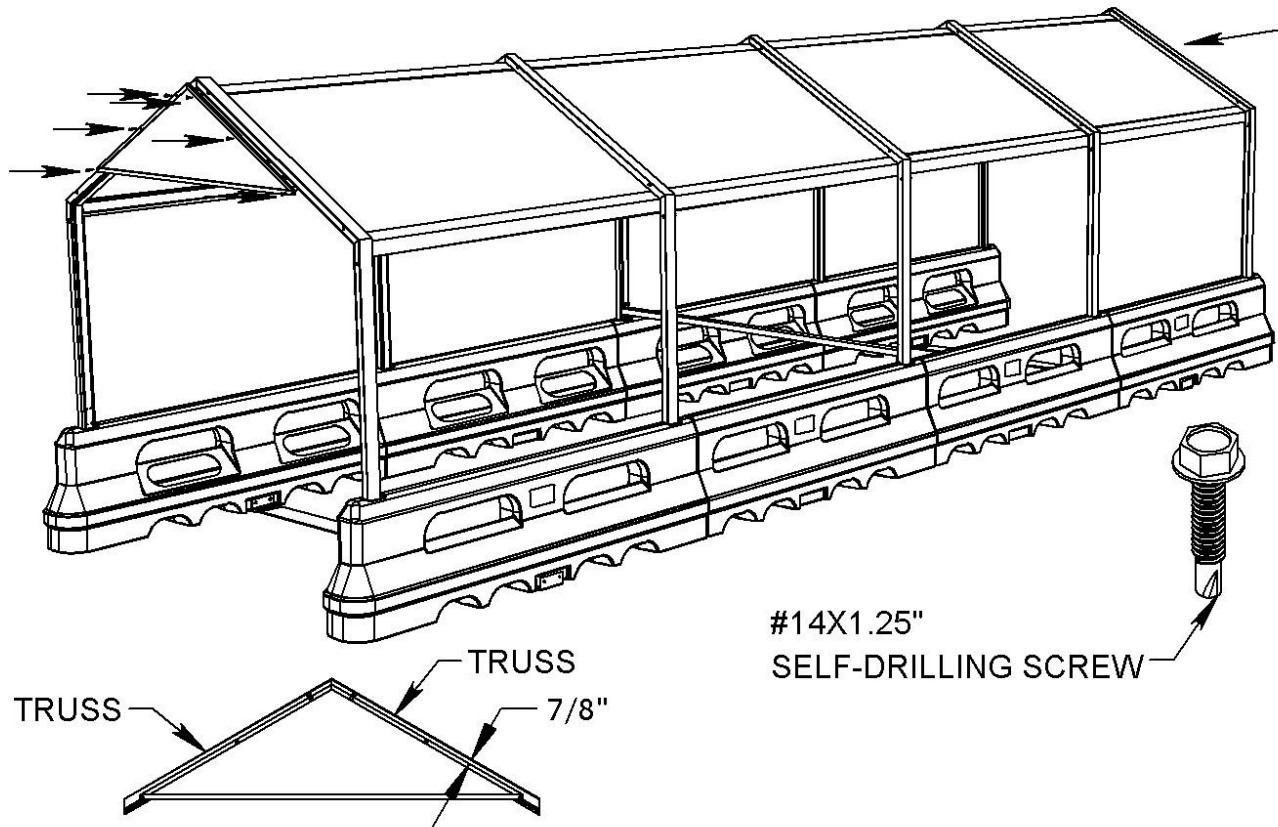

Step 10: Ballast with pea stone or gravel

It is important to ballast the CartPark unit with sand, pea stone or gravel. Fill each barrier with 300 lbs of sand, pea stone or gravel for a total of 2,400 lbs. There are two holes in each barrier. Balance the weight in each barrier by pouring half of the sand, pea stone or gravel into one hole and the other half into the other hole. Cover each hole with a barrier cap and secure barrier caps into place using two (2) 14x1.25" self-drilling screws.

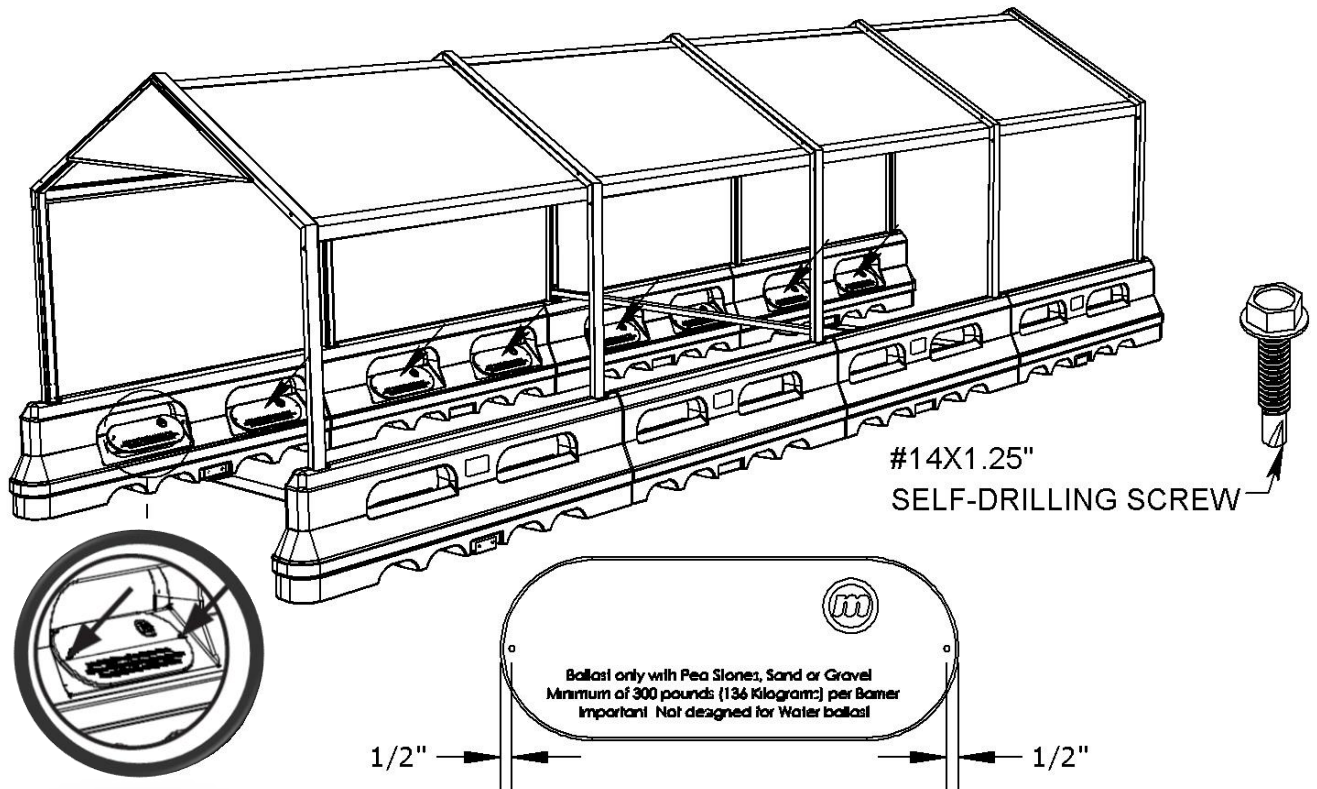

Step 12: Finished Unit

