

CRASHBARRIER PLUS+

THE GLOBAL STANDARD
FOR INDUSTRIAL SAFETY
BARRIER INNOVATION

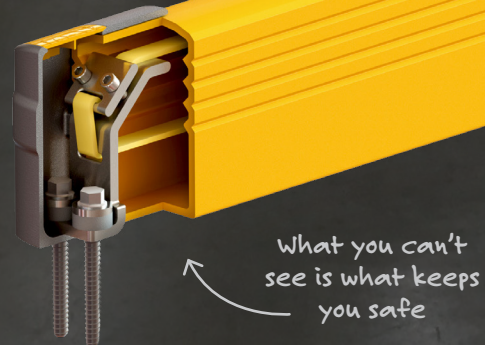

THE MCCUE DIFFERENCE

HI, WE'RE MCCUE & WE MAKE SAFETY EASY!

Our design philosophy is simple, innovate with our customers every day to solve their most difficult safety problems. **CrashBarrier PLUS+** was engineered with that methodology and is revolutionizing safety barrier innovation with these three principals:



SUPER STRENGTH

Designed to stop today's modern forklifts



ENERGY ABSORPTION

Impact-absorbing barrier keeps your people safer



ULTIMATE ADAPTABILITY

Endless configurations ensure the perfect fit

DON'T LET YOUR FACILITY OF TOMORROW BE HELD BACK BY THE SAFETY BARRIERS OF YESTERDAY - UPGRADE TODAY (800) 800-8503!



McCue

HIDDEN HARDWARE:

Internal hardware means less tripping and shearing, not to mention better looks!

SMALL FOOTPRINT:

Keep your facility at peak efficiency and maximize your space.

MATERIAL SELECTION:

Polymers, ductile iron, synthetic straps, elastomers — all combined to put in the work when you need it and look damn good when you don't.

ENGINEERING & DESIGN:

Everything great about our standard **Crash Barrier**, **PLUS** patent-pending reinforcement technology for even more stopping power.

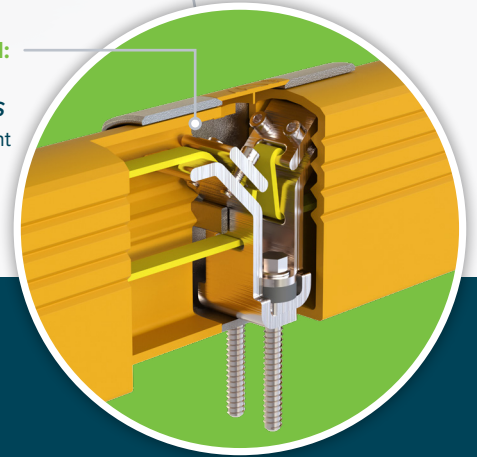

CRASHBARRIER PLUS+

Meet **CrashBarrier PLUS+**, the strappingly strong safety barrier designed to keep your facility safe and your people safer. Pairing patented impact-absorbing technology with a woven synthetic spine, **CrashBarrier PLUS+** provides unparalleled energy dissipation to bring errant forklifts to a slower and safer stop.

INTENDED USES



PEDESTRIAN WALKWAYS

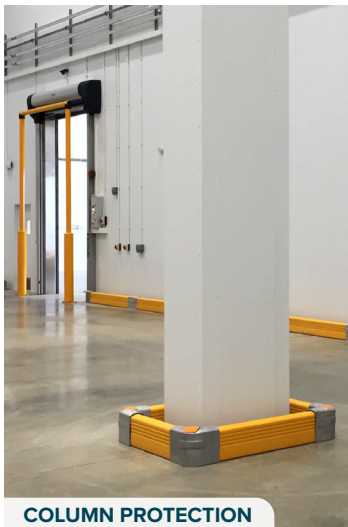

COLUMN PROTECTION



WALL PROTECTION



RACK PROTECTION

* PATENTS PENDING

IMPACT TESTING

How we determine the stopping power of a barrier.

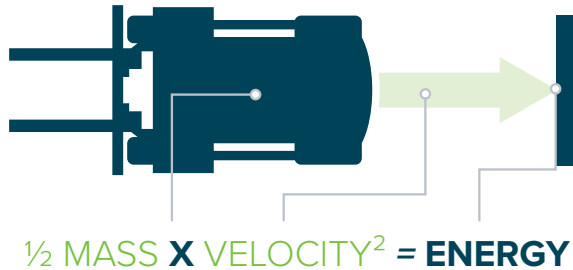

Dynamic Impact Test
15,492 ft lbs (21,004 J)





10,022 lbs
(4,545.9 kg)

6.8 mph
(10.9 kmh)

90°	15,492 ft lbs	21,004 J	45°	21,912 ft lbs	29,708 J	30°	30,984 ft lbs	42,008 J
------------	----------------------	-----------------	------------	----------------------	-----------------	------------	----------------------	-----------------

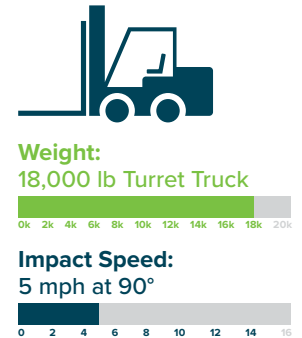
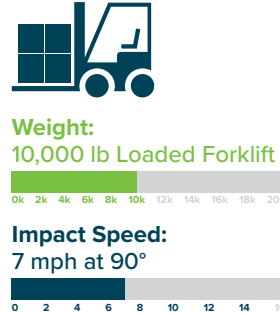
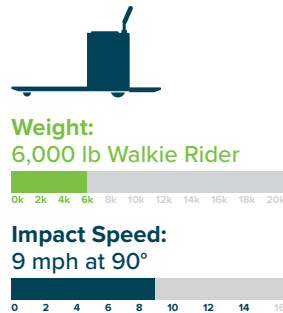
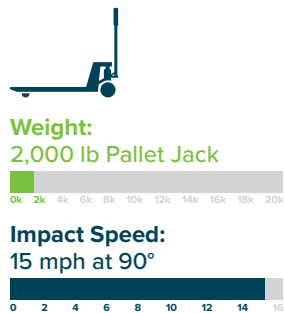
WHAT DOES 15,500 FT LBS (21,000 J) MEAN TO YOU?



MATERIAL PROPERTIES

BARRIER DEFLECTION: The bend but don't break mentality.

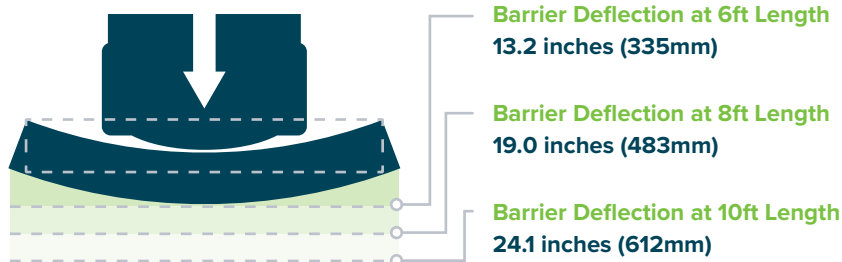

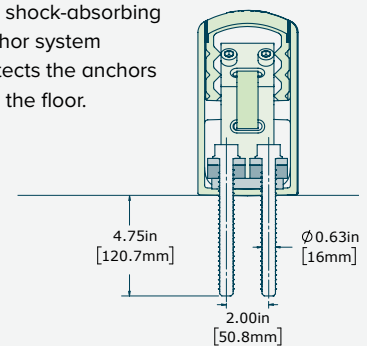

Anchor Specifications:

The shock-absorbing anchor system protects the anchors and the floor.



	Working Temperatures	32°F-130°F (0°C-54°C)
	Toxicity	Not Hazardous

	Flammability	Does Not Easily Ignite
	REACH / RSCA / DSL	Compliant

* PATENTS PENDING

CRASHBARRIER *PLUS+*



CRASHBARRIER END PART NUMBER: CB-K-END-307

What's Included: Ductile Iron End, (2) Shock-Absorbing Concrete Anchors, Polymer Cap



CRASHBARRIER MID PART NUMBER: CB-K-MID-307

What's Included: Ductile Iron Mid, (2) Shock-Absorbing Concrete Anchors, Polymer Cap



CRASHBARRIER CORNER PART NUMBER: CB-K-CNR-307

What's Included: Ductile Iron Corner, (2) Shock-Absorbing Concrete Anchors, Polymer Cap



CRASHBARRIER POST END PART NUMBER: CB-K-PSE-307

What's Included: Ductile Iron Post End, (2) Shock-Absorbing Concrete Anchors, Polymer Cap

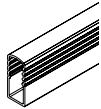

BARRIER PART NUMBER: CB-C-EXTPLUS-307

What's Included: (1) Polymer Barrier, 10' (3 m) length



PLUS+ END / MID KIT PART NUMBER: CB-K-STP-ADJ

What's Included: (2) CrashBarrier PLUS+ End/Mid Brackets, 12' High Strength Nylon Strap



PLUS+ CORNER KIT PART NUMBER: CB-K-STP-CNR-ADJ

What's Included: (2) CrashBarrier PLUS+ Corner Brackets, 12' High Strength Nylon Strap

TECHNICAL *SPECS*

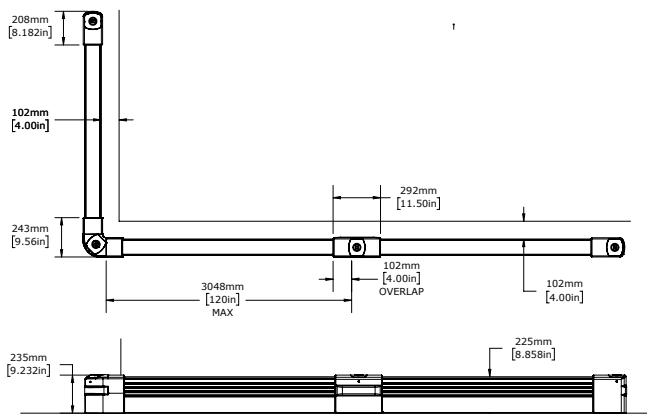

Example Includes:

- (2) CrashBarrier Ends: CB-K-END-307
- (1) CrashBarrier Corner: CB-K-CNR-307
- (1) CrashBarrier Mid: CB-K-MID-307
- (3) Barriers: CB-C-EXTPLUS-307
- (2) PLUS+ End/Mid Kit: CB-K-STP-ADJ
- (1) PLUS+ Corner Kit: CB-K-STP-CNR-ADJ

