

**COVER OPTIONS**

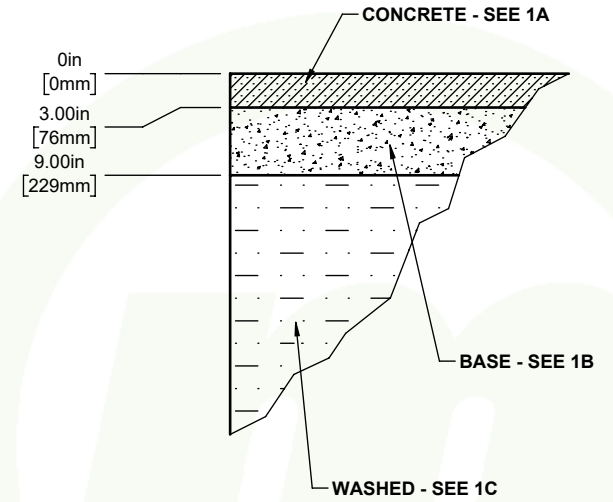
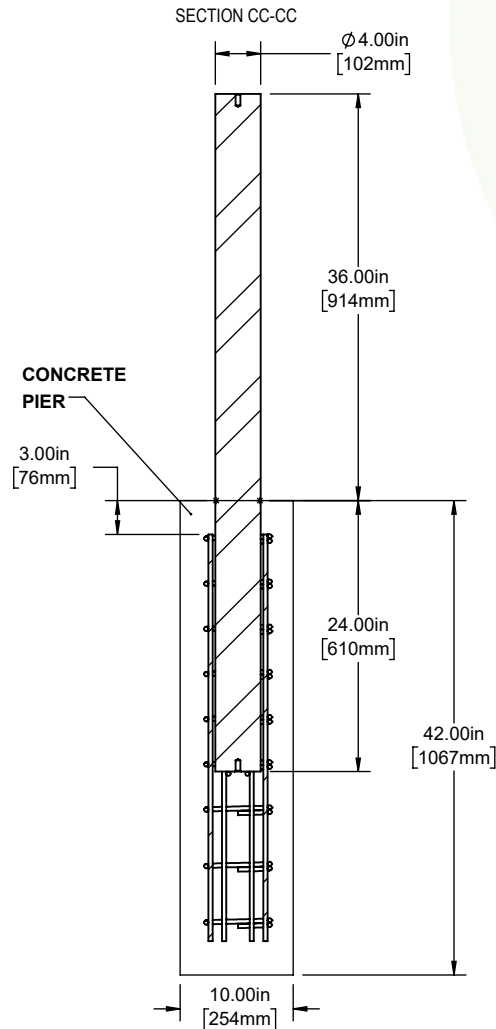
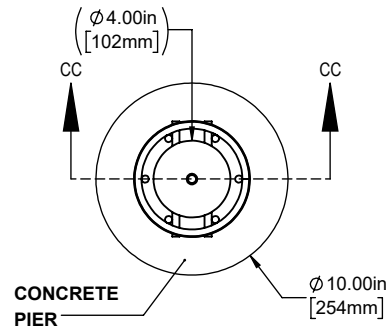
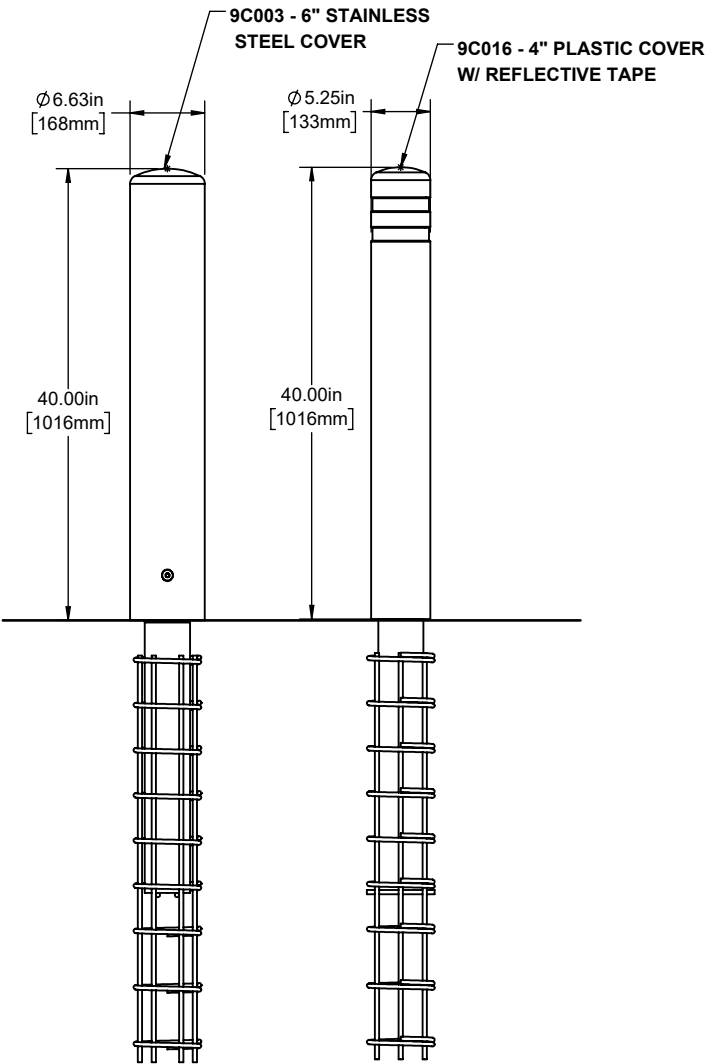

**GROUND CONDITIONS**

- 1a: The concrete is 3000 psi minimum unconfined compressive strength, with one layer of #3 (Ø3/8") rebar spaced at 12" each way, with 1-1/4" cover at bottom. Rebar not shown here.
- 1b: The base is Type A Grade 1 crushed limestone road base, compacted to 90% of standard proctor density.
- 1c: The washed sand shall be classified as SP - poorly graded sand & be compacted to a density of not less than 90% maximum dry density in accordance with AASHTO Method of Test T099.

**Customer Drawing**  
**CRASHCORE S20**



**McCue US**  
(978) 741 8500  
CustomerCare@mccue.com

**McCue UK**  
+44 1908-365-511  
UKCServices@mccue.com

**McCue China**  
+86-592-2200 790  
ChinaOffice@mccue.com

[mccue.com](http://mccue.com)