

COVER OPTIONS

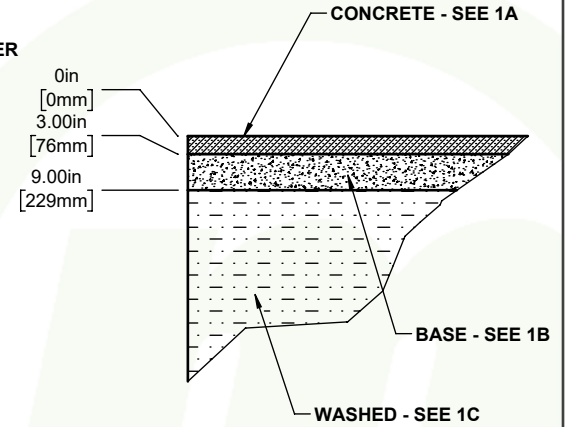
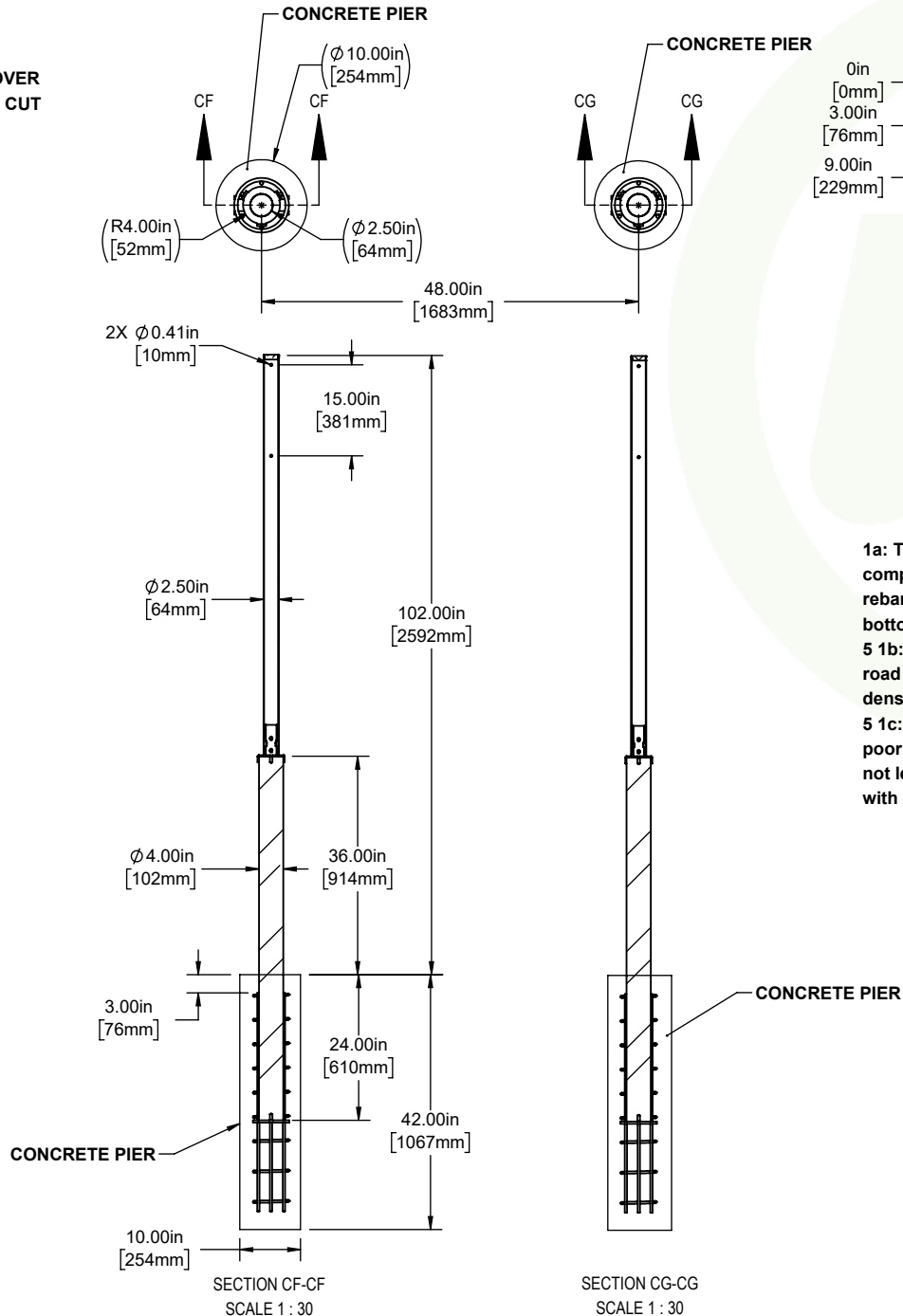
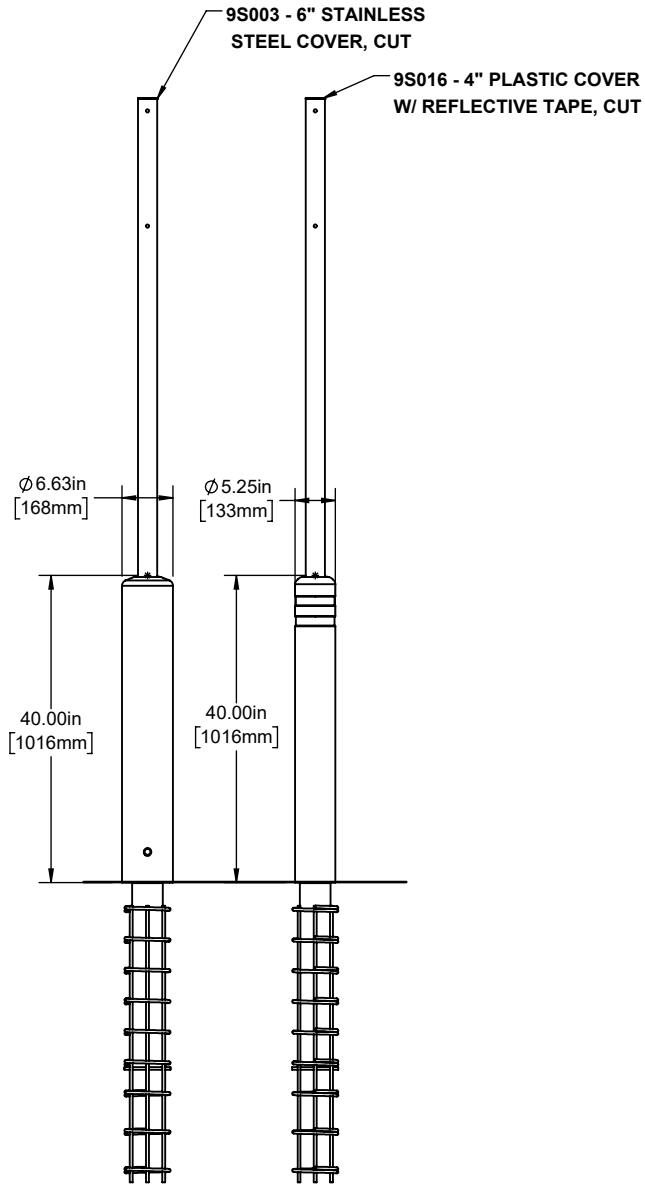

1a: The concrete is 3000 psi minimum unconfined compressive strength, with one layer of #3 (Ø3/8") rebar spaced at 12" each way, with 1-1/4" cover at bottom. Rebar not shown here.

5 1b: The base is Type A Grade 1 crushed limestone road base, compacted to 90% of standard proctor density.

5 1c: The washed sand shall be classified as SP - poorly graded sand & be compacted to a density of not less than 90% maximum dry density in accordance with AASHTO Method of Test T099.

Customer Drawing
CRASHCORE S30 SIGN

McCue US
(973) 741 8500
CustomerCare@mccue.com

McCue UK
+44 1908-365-511
UKCServices@mccue.com

McCue China
+86-592-2200 790
ChinaOffice@mccue.com

mccue.com

PROPRIETARY-CONFIDENTIAL: This document contains information proprietary to McCue Corporation. This information is not to be used in any way, disclosed to others or reproduced, in whole or in part, except as expressly authorized in writing by McCue Corporation. Any reproduction of this document, in whole or in part, must include this notice.