



mccue.com 
SalesUS@mccue.com 
(800) 800-8503 



PEDESTRIANBARRIER GATE ACCESSORY

**ASSET PROTECTION
STARTS WITH
YOUR PEOPLE**

THE MCCUE DIFFERENCE

HI, WE'RE MCCUE & WE MAKE SAFETY EASY!

Our fully modular pedestrian systems keep your people safe and your business protected. Incorporate a gate into PedestrianBarrier to help employees cross at designated areas while helping them be more attentive in high-traffic areas.

**KEEP YOUR OPERATIONS SAFE AND YOUR WORKFORCE SAFER WITH THE WORLD'S MOST
ADVANCED SAFETY BARRIERS — SPEAK TO A SAFETY SPECIALIST TODAY (800) 800-8503**



SMART DESIGN:

No springs means your gate will last longer and continue working to the highest standard.



NO CATCHING POINTS:
Eliminate major pinching points.

COMPLETE PROTECTION:
Auto-closing will always close behind you at a safe and slow speed.

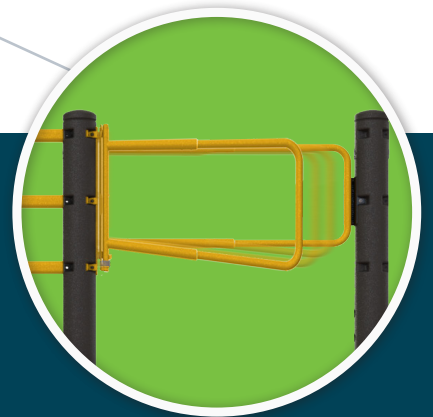

PEDESTRIAN BARRIER GATE ACCESSORY



PEDESTRIAN BARRIER *GATE*

PedestrianBarrier Gate

PB-C-GTL-307

Materials: Polypropylene rails, nylon cam, steel hinge & latch.

Mounting hardware included.
 Post not included.

Lead Time

4 week lead time

