



SAFESTOP BOLLARD 15

**INNOVATIVE, INDUSTRIAL
SAFETY BOLLARDS KEEP
YOUR PEOPLE SAFE**

Shock-absorbing
base provides
ultimate stopping
power



THE MCCUE DIFFERENCE

HI, WE'RE MCCUE & WE MAKE SAFETY EASY!

Our innovative, impact-tested bollards safely stop moving material handling vehicles — protecting your people and your facility. With engineered materials that work together, we're revolutionizing safety barrier innovation with these three principles:



SUPERIOR STRENGTH

Designed to bring heavy machinery to a safe stop.



ENERGY ABSORPTION

Absorbs impacts to keep your people and your operations safe.



EASY INSTALL

Simple 4-anchor install with standard hardware and tools.

**KEEP YOUR OPERATIONS SAFE AND YOUR WORKFORCE SAFER WITH THE WORLD'S MOST
ADVANCED SAFETY BARRIERS — SPEAK TO A SAFETY SPECIALIST TODAY (800) 800-8503**



SAFER STOPS: Bollard absorbs impact energy and attenuates shock to keep your people and equipment safe.

IMPACT ENERGY

CLEAN FINISH: Internal hardware means no catching points, not to mention better looks!



EASY INSTALLATION: With 4 concrete anchors, SafeStop Bollards are easy to install and relocate.

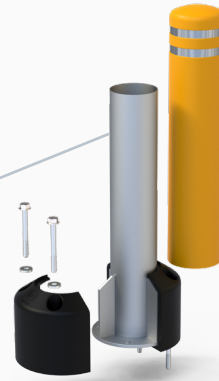

ULTIMATE STRENGTH: A proprietary blend of synthetic elastomer and high strength steel absorbs impact energy.

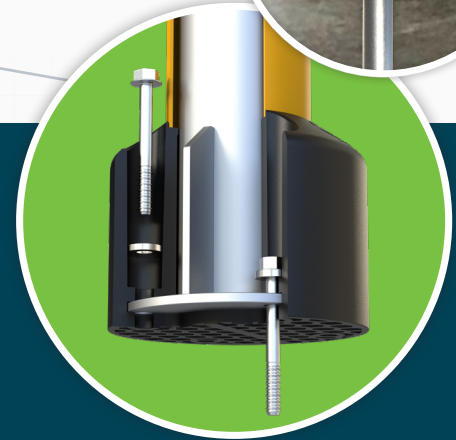
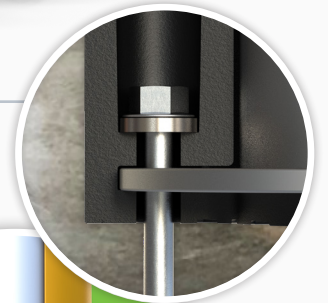

SAFESTOP BOLLARD 15

Meet **SafeStop Bollard 15**, our impact-absorbing bollard engineered to stop heavy equipment. **SafeStop Bollard 15** safely absorbs and withstands impacts up to 15,000 J, keeping your people safe and your facility damage-free.

SIMPLE INSTALLATION

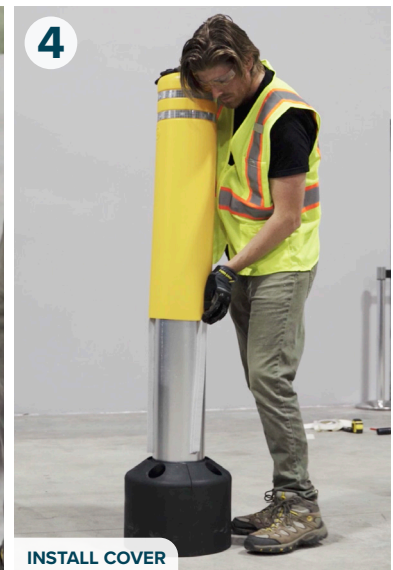

To see complete instructions, visit www.mccue.com!

* PATENTS PENDING

IMPACT TESTING

Rigorous product testing at the highest standard.

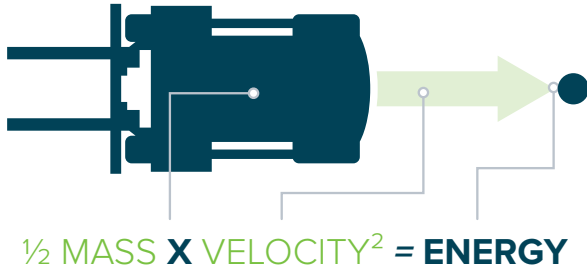

Dynamic Impact Test
11,073 ft-lbs (15,013 J)

 **x** 

13,250 lbs (6010 kg) **5.00 mph (8.05 kmh)**

90°	11,073 ft-lbs	15,013 J
------------	----------------------	-----------------

45°	15,660 ft-lbs	21,232 J
------------	----------------------	-----------------

30°	22,143 ft-lbs	30,022 J
------------	----------------------	-----------------

WHAT DOES 11,073 FT LBS (15,013 J) MEAN TO YOU?

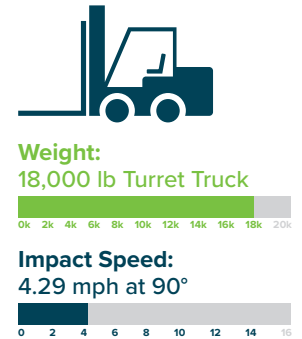
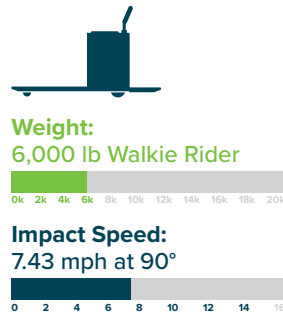
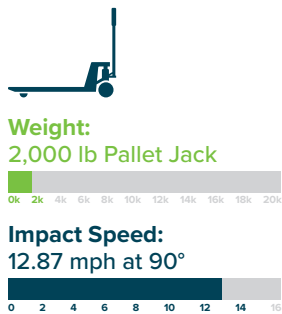

MATERIAL PROPERTIES

BOLLARD DEFLECTION: The bend but don't break mentality.

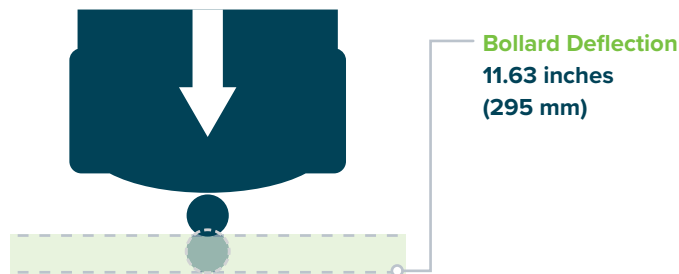

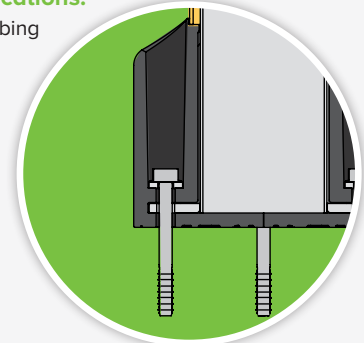

Anchor Specifications:

The shock-absorbing anchor system protects the anchors and the floor.



	Working Temperatures	-10°F-130°F (-23°C-54°C)
	Toxicity	Not Hazardous

	Flammability	Does Not Easily Ignite
	REACH / RSCA / DSL	Compliant

* PATENTS PENDING

SAFESTOP **BOLLARD 15**

SafeStop Bollard 15
PART NUMBER: 1C603

Hardware included
 Packed: 1 per box

LEAD TIME: 3 week lead time for quantities 1-24 . For larger quantities, please call for lead time and pricing.

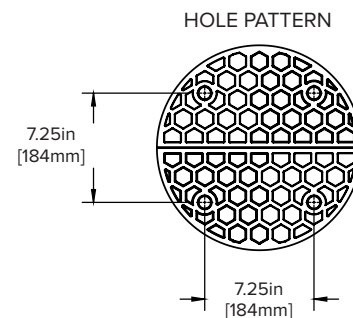
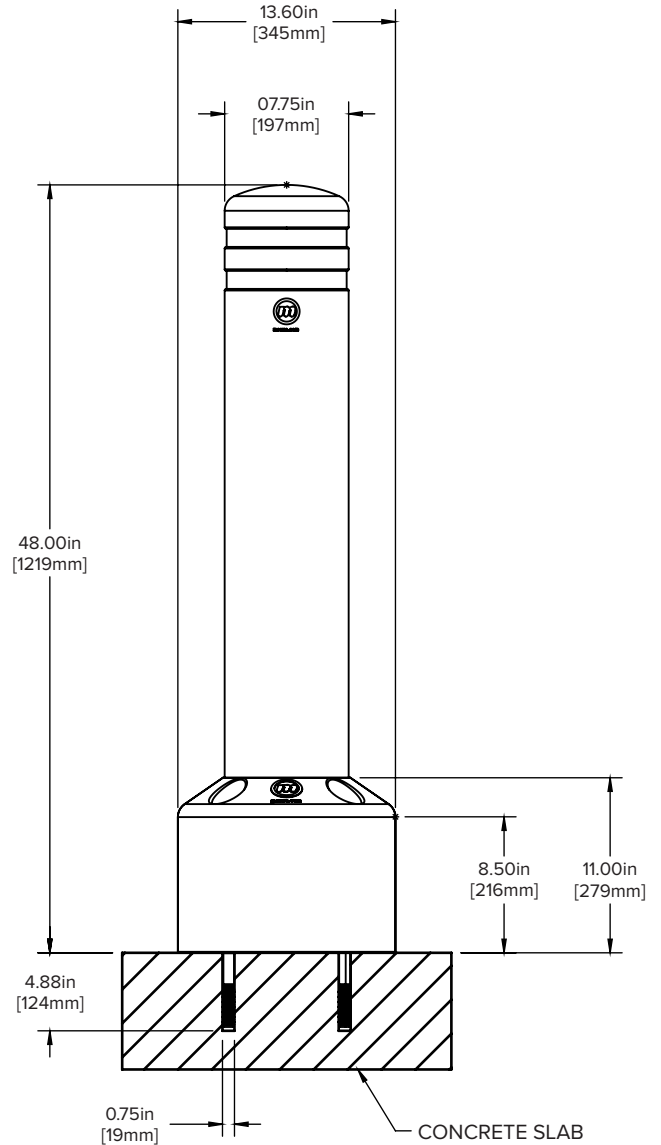

* PATENTS PENDING