

Goal Post

INSTALLATION INSTRUCTIONS

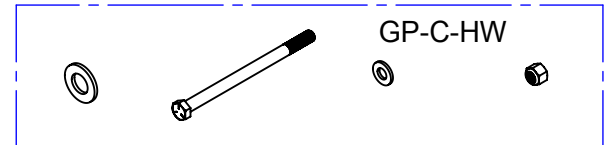
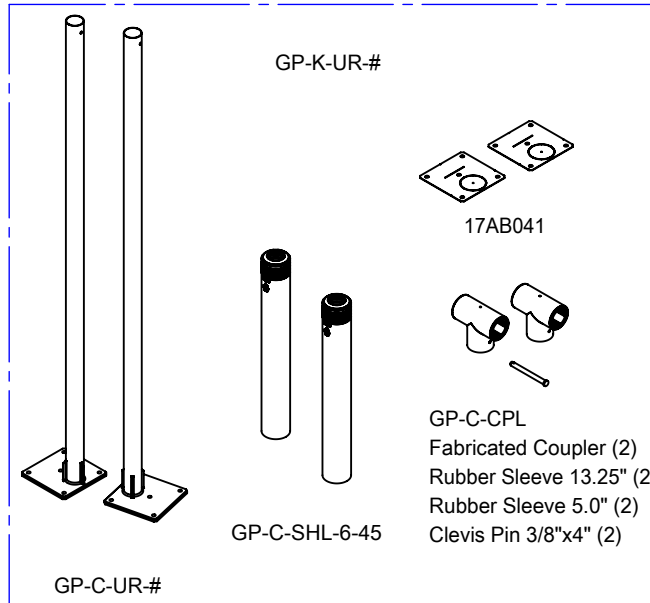
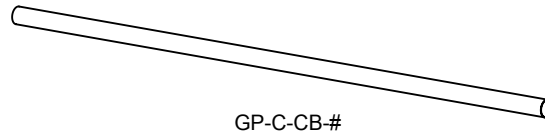
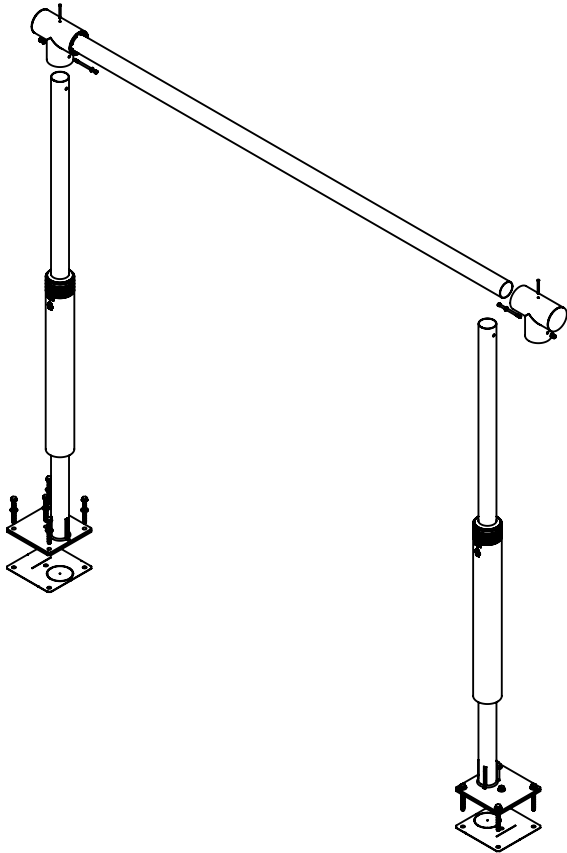

LDT-3470

FLAT WASHER
15/16" ID & 1/2" ID

HEX BOLT
1/2-13X7.5"

FLAT WASHER
1/2" ID

LOCK NUT
1/2-13

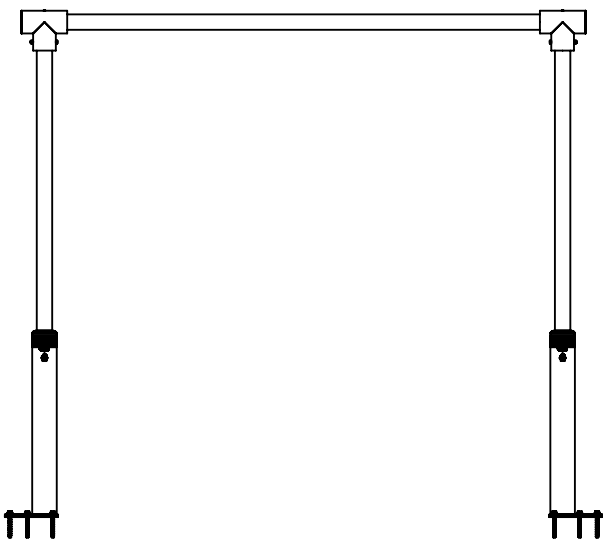
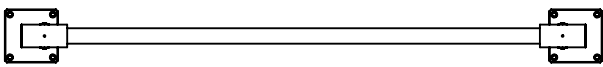

Tools Required

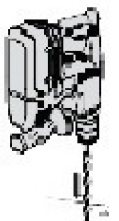
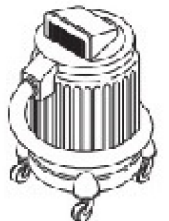

McCue Corporation
Peabody, Massachusetts, USA
+1 (800) 800 8503
customer@McCue.com

McCue UK & Europe
Milton Keynes, United Kingdom
+44 (0)1908 365 511
uksales@McCue.com

McCue Asia
迈客(厦门)有限公司
Xiamen, Fujian, China
+86-592-2200790

McCue.com



① MEASURE INTERNAL OPENING WIDTH AND HEIGHT OF DOOR AND RECORD.

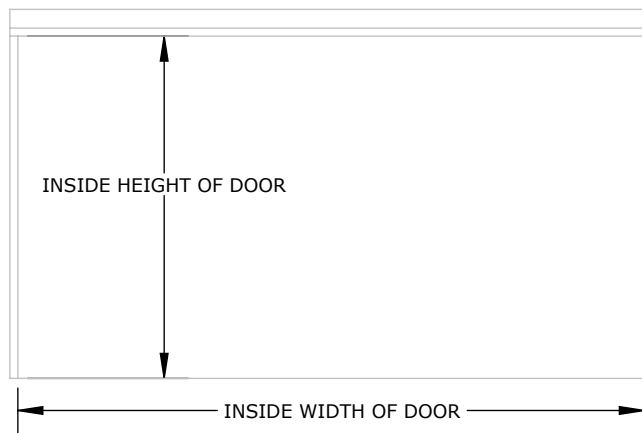

② DETERMINE HOW FAR FROM THE ENTRANCE YOU WOULD LIKE TO INSTALL GOAL POST AND SNAP
A CHALK LINE 16" PAST BOTH OUTSIDE EDGES OF THE ENTRANCE.
LOCATE THE TEMPLATES CENTERED WITH CHALK LINE AS SHOWN IN DETAIL -B- AND ALIGN THE DOOR EDGES TO THE
MARKS SHOWN IN DETAIL -A-,
MEASURE BETWEEN THE TEMPLATE LINES TO GET YOUR CROSS BAR LENGTH. MARK AND DRILL 3/4" DIAMETER
HOLES X 6.5" DEEP USING A HAMMER DRILL.

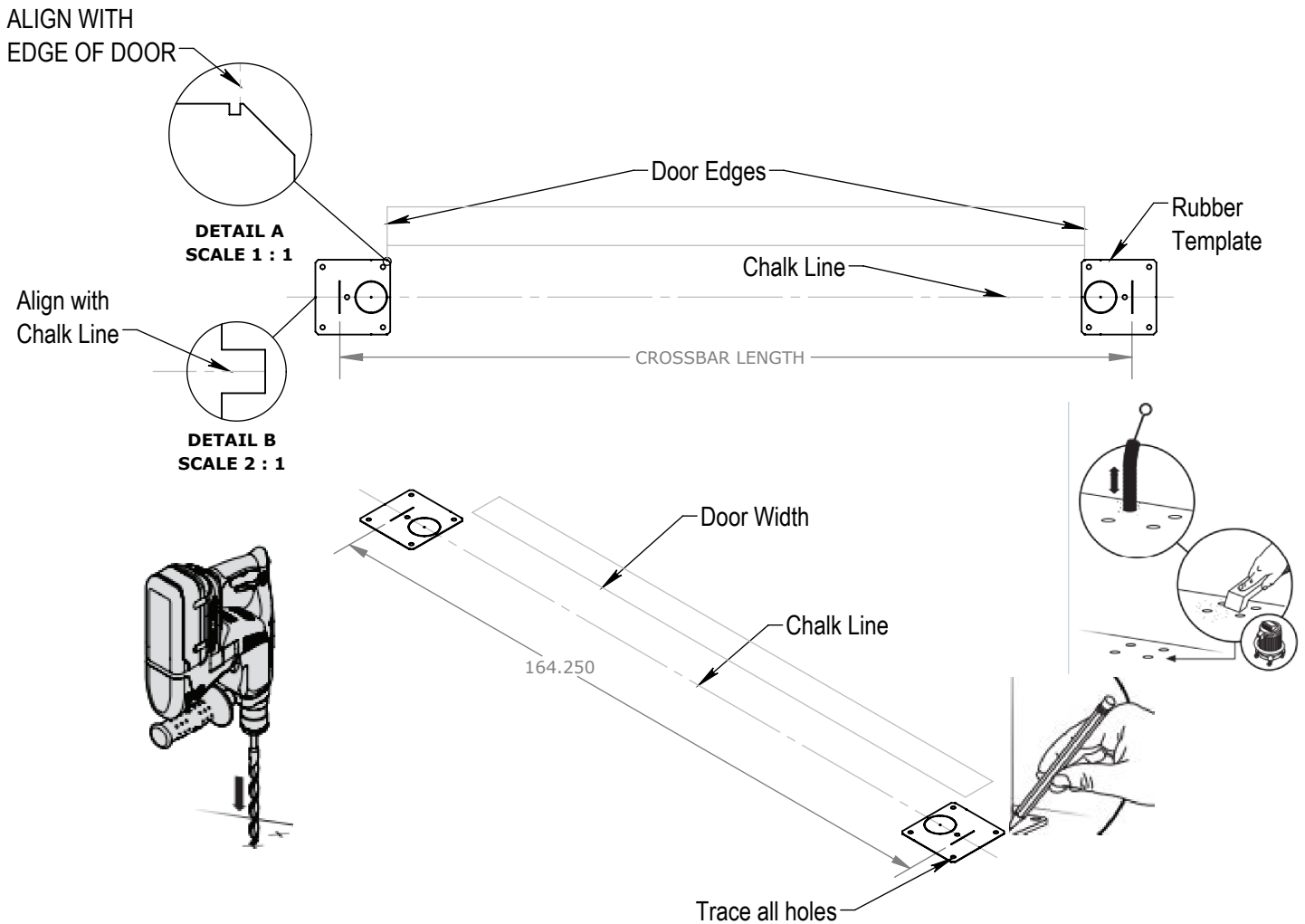

③ CUT UPRIGHTS IF NEEDED (YES OR NO) IF YES, SUBTRACT 2.0" FROM THE HEIGHT OF THE DOOR AND MARK UPRIGHT. CUT BOTH POST TO SAME DESIRED HEIGHT. DEBURR OR FILE ANY SHARP EDGES. NOTE; THIS WILL LOCATE THE BOTTOM EDGE OF CROSSBAR FLUSH WITH OPENING OF DOOR.

USING YOUR COUPLERS AS JIG, INSERT COUPLER ON CUT END UNTIL FLUSH AND MARK THE 1/2" DIAMETER HOLES. REMOVE COUPLER AND DRILL (2) 5/8" (0.625") DIAMETER HOLES ON BOTH SIDES OF EACH POST. ENSURE HOLES ALIGNMENT WITH COUPLERS, BY INSERTING THE 1/2"-13X7.5" LONG HEX BOLTS THRU BOTH COMPONENTS.

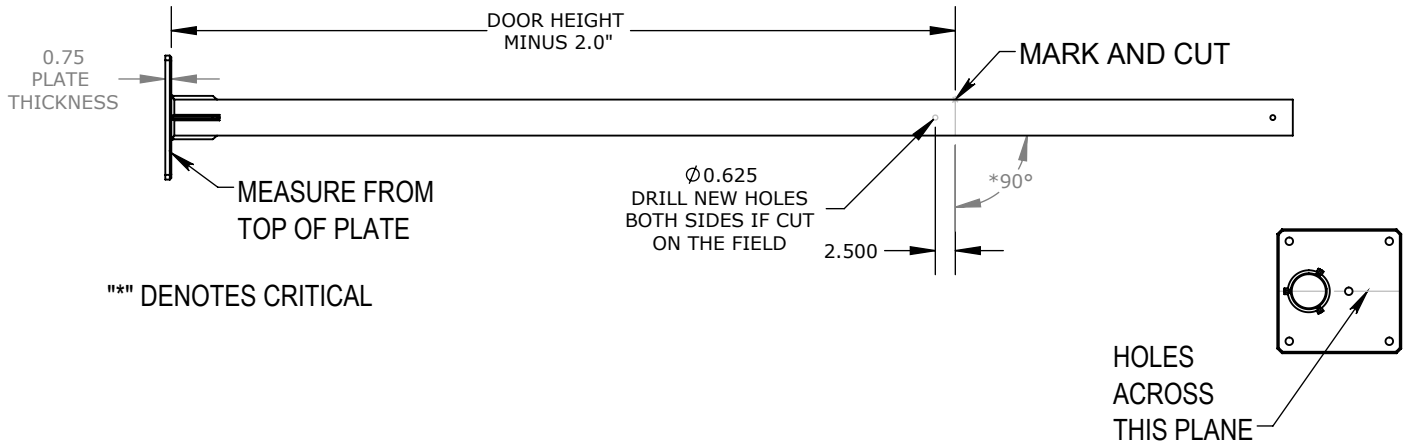

④ CUT CROSSBAR IF NEEDED (YES OR NO) IF YES, MEASURE BETWEEN THE RUBBER TEMPLATE LINES TO GET YOUR WIDTH. DOUBLE CHECK YOUR WIDTH PRIOR TO CUTTING. USE A METAL CUTTING BLADE TO CUT CROSSBAR THRU. CLEAN CUT EDGES IF NEEDED WITH A METAL FILE.

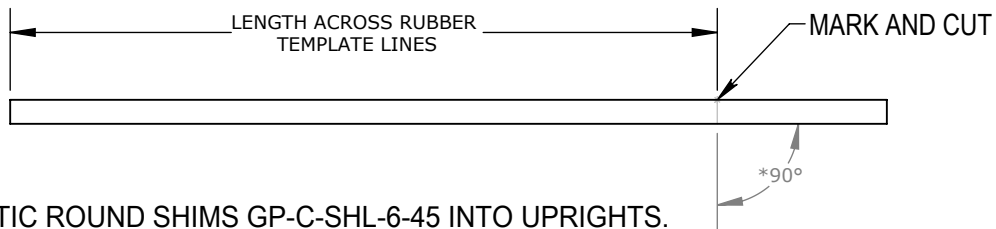

⑤ SLIDE PLASTIC ROUND SHIMS GP-C-SHL-6-45 INTO UPRIGHTS.

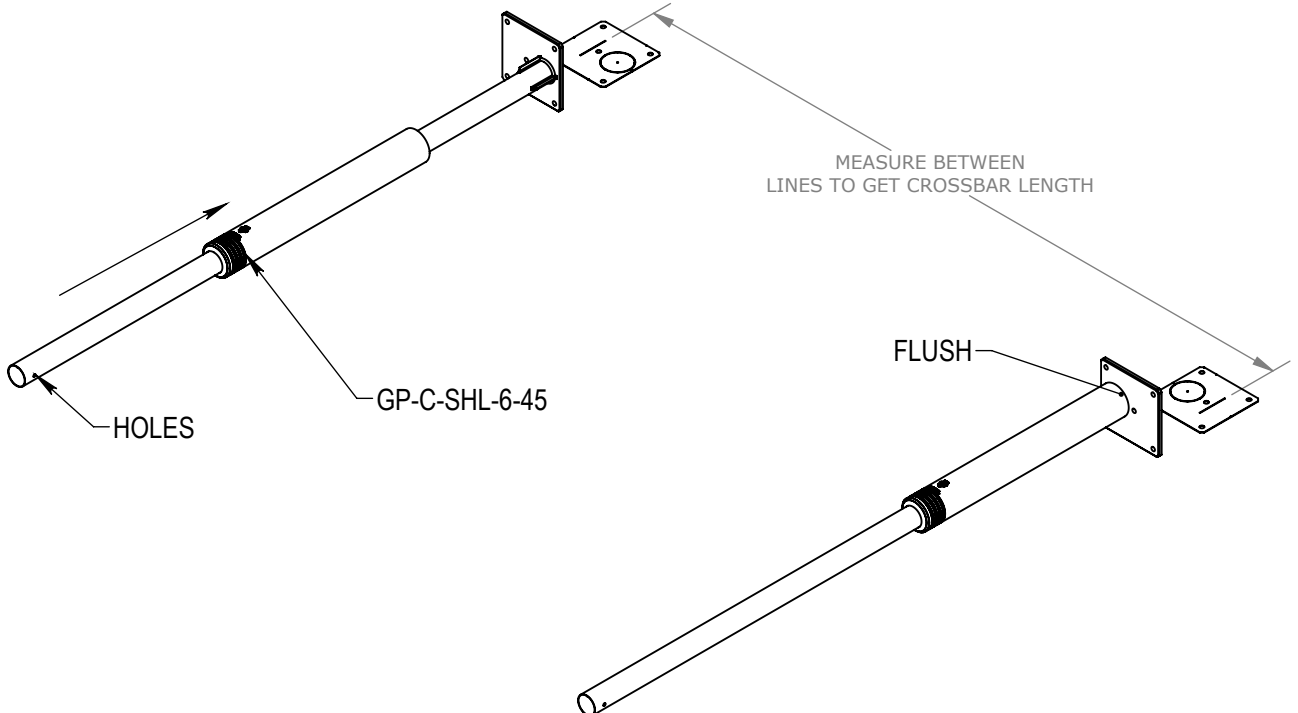

⑥ STAND UPRIGHT OVER RUBBER TEMPLATE, ALIGN ALL THE HOLES AND SECURE POST TO CONCRETE WITH (5) 3/4"X 7.0" ANCHORS AND (5) FLAT WASHERS UNTIL FLUSH WITH TOP OF PLATE. MAKE SURE ALL FASTENERS ARE TIGHT.

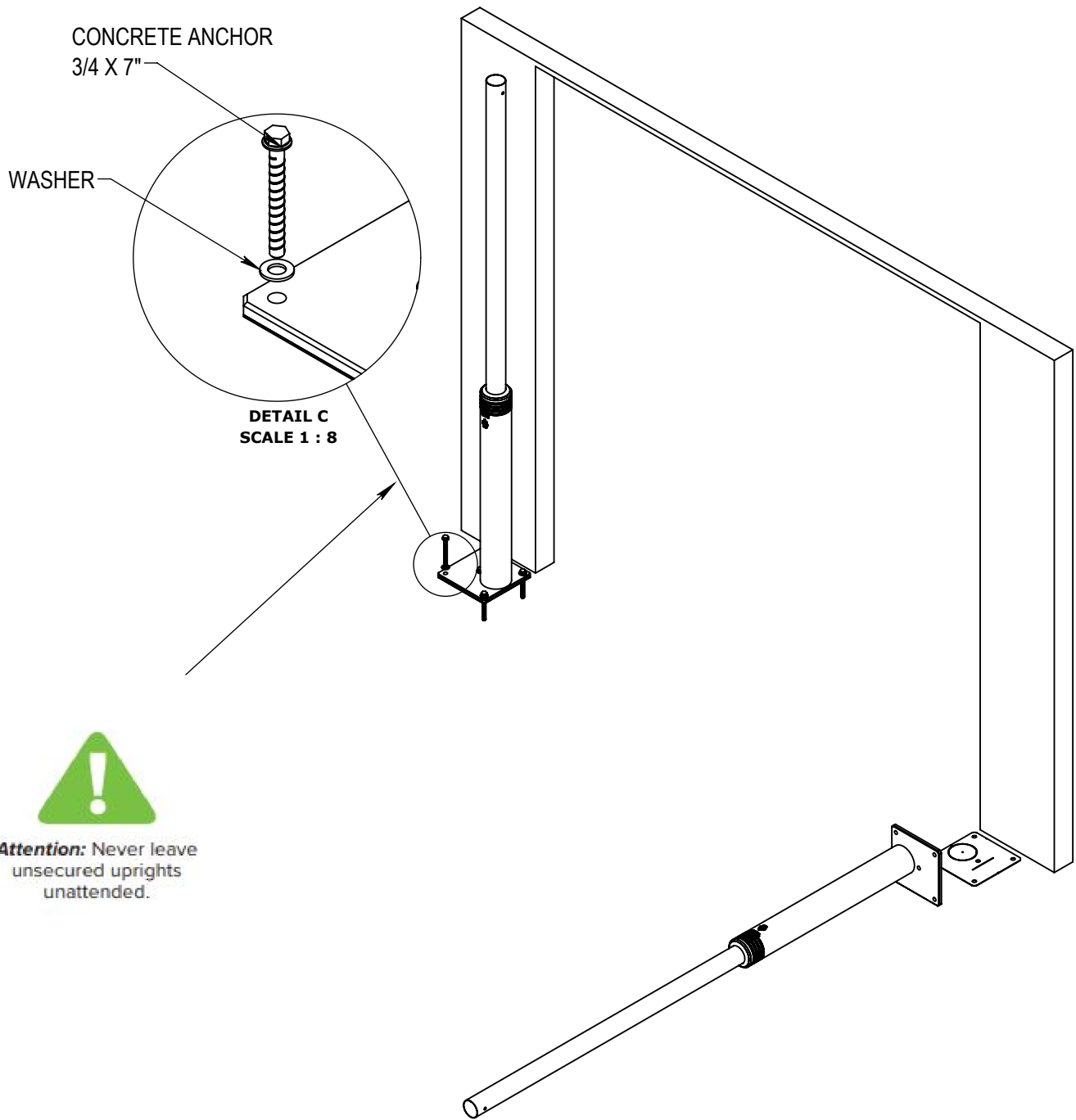

⑦ STAND UPRIGHT OVER RUBBER TEMPLATE, ALIGN ALL THE HOLES AND SECURE POST TO CONCRETE WITH (5) 3/4" X 7.0" ANCHORS AND (5) FLAT WASHERS UNTIL FLUSH WITH TOP OF PLATE. MAKE SURE ALL FASTENERS ARE TIGHT.

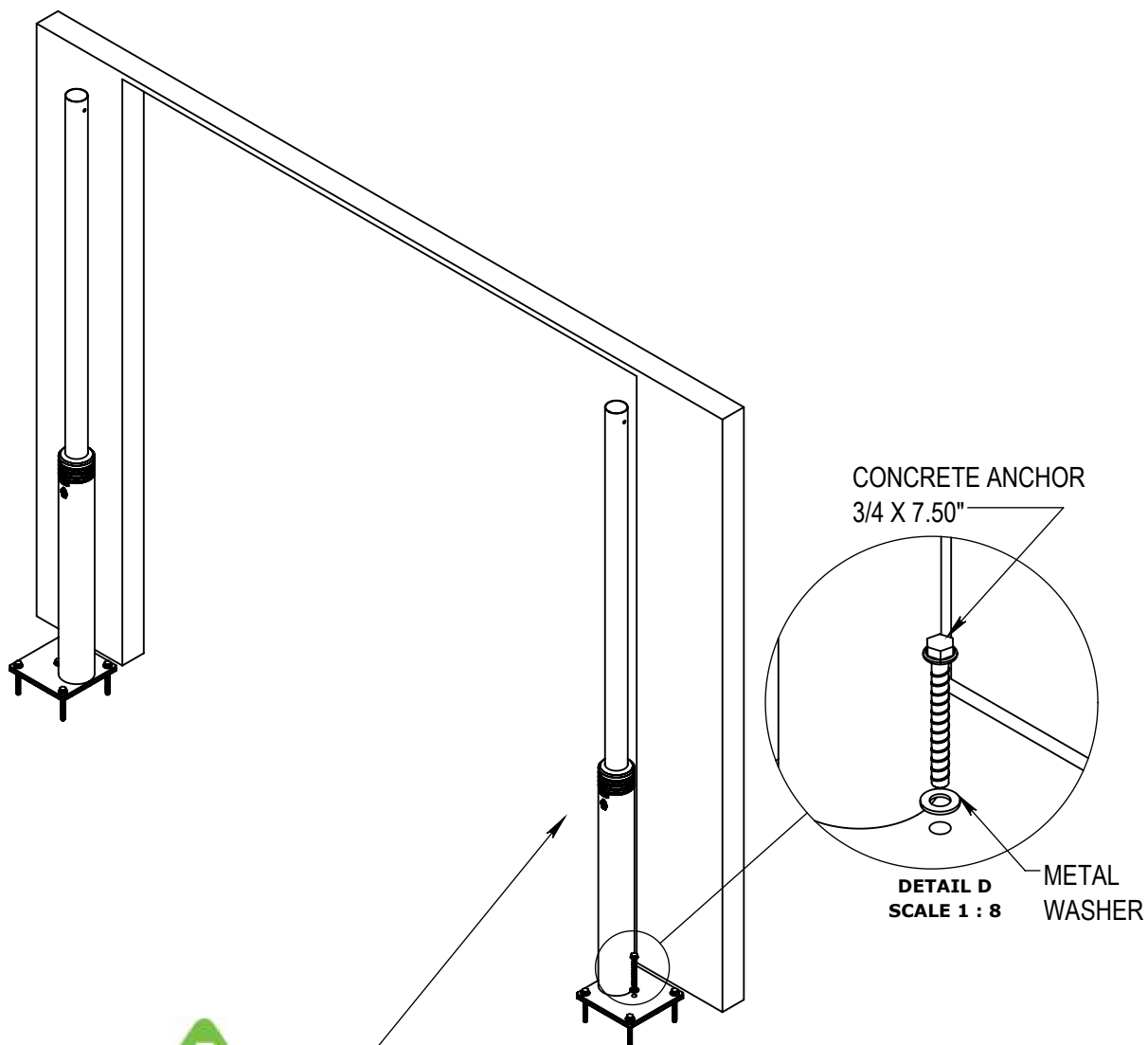

Attention: Never leave unsecured uprights unattended.

8 USING A SCISSOR LIFT, SLIDE COUPLERS ON THE CROSSBAR ENDS, AND SLIDE ONTO POSTS.

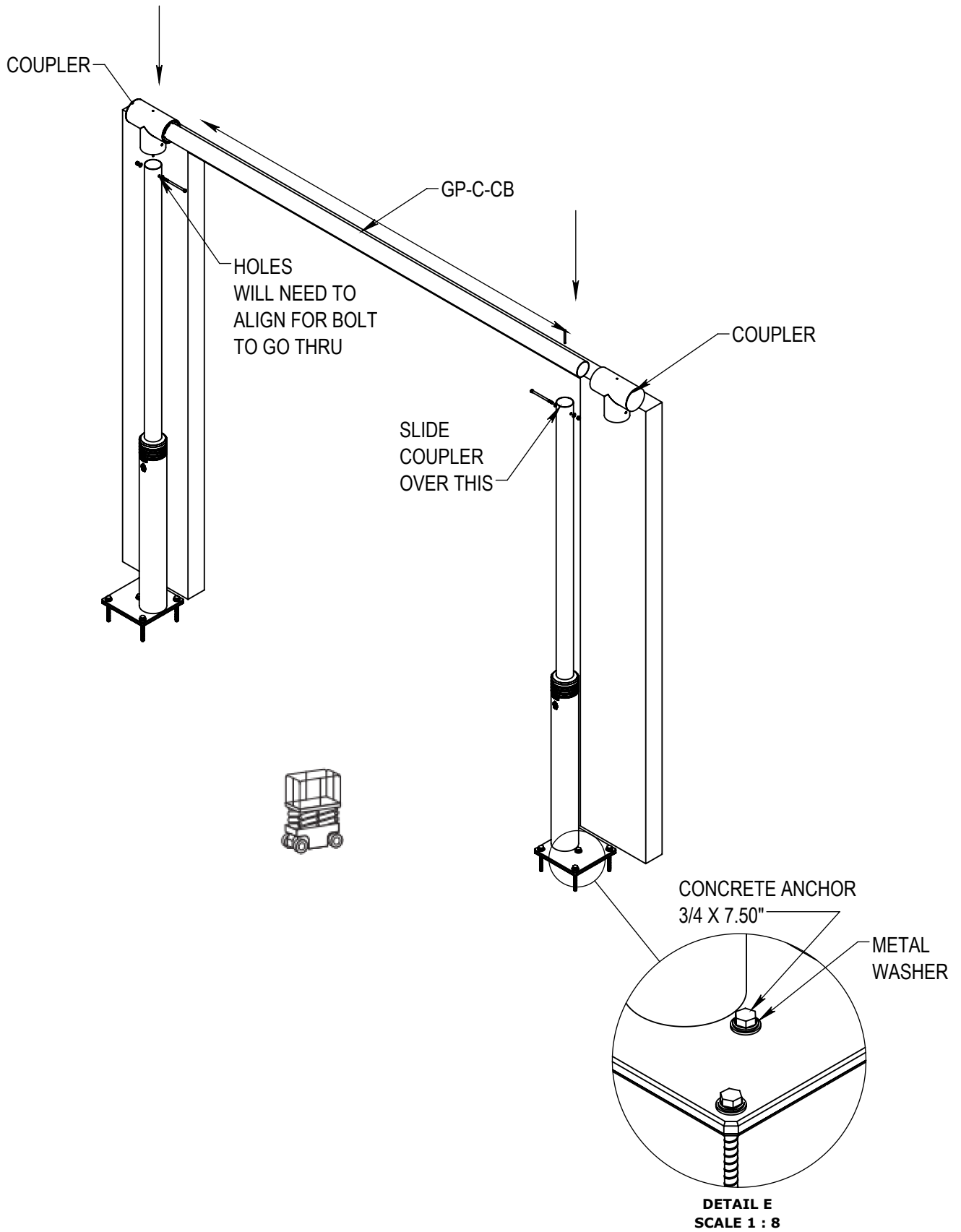

⑧ IMPORTANT:
BOLT EACH COUPLER TO UPRIGHT WITH (1) 1/2"-13 X 7.50" LONG HEX HEAD BOLTS, (2) FLAT WASHERS,
(2) 1/2"-13 NYLON LOCK NUTS.

DRILL 3/8" DIAMETER HOLE AT THE TOP OF THE CROSSBAR AND SLIDE ONE (1) 3/8"X4.0" CLEVIS PIN
THRU THE TOP

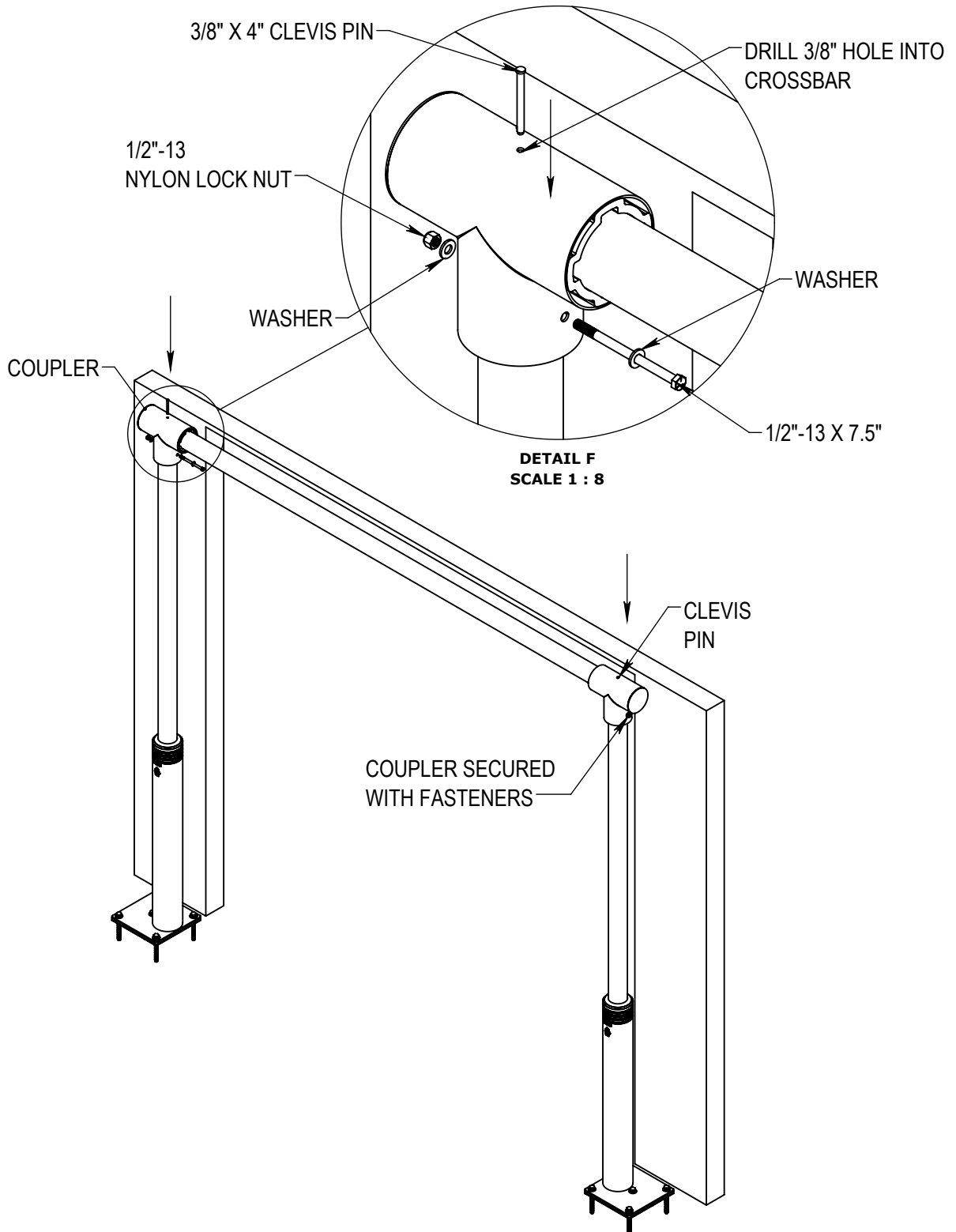

9) GOAL POST IS COMPLETE WHEN ALL FASTENERS ARE SECURED AND CLEVIS PINS ARE INSTALLED.

