

Protecting Your Doors from Impact

We engineered our goalpost door protection to withstand direct impacts from heavy equipment, spinning and lifting to absorb damaging forces. Best of all, they install fast—thanks to patent pending coupler that lets each support pipe to install independently with no welding.

Energy Absorbing Design Goal Post bollard shell, spin and lift to absorb impact forces and the patent pending shock-absorbing crossbar coupler softens impacts to the crossbar

Complete Protection Post and rail system protects the entire door area

Quick Installation Installs in minutes — without welding — and protects doors for years



Goal Post

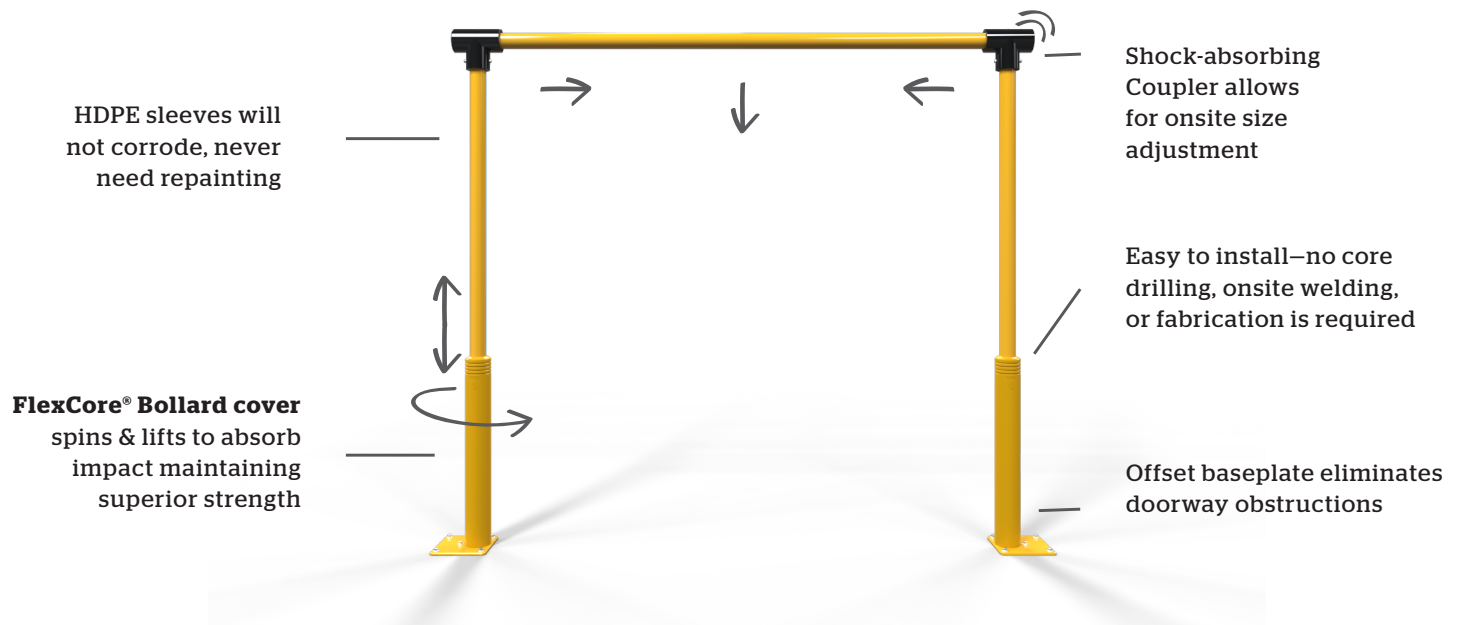
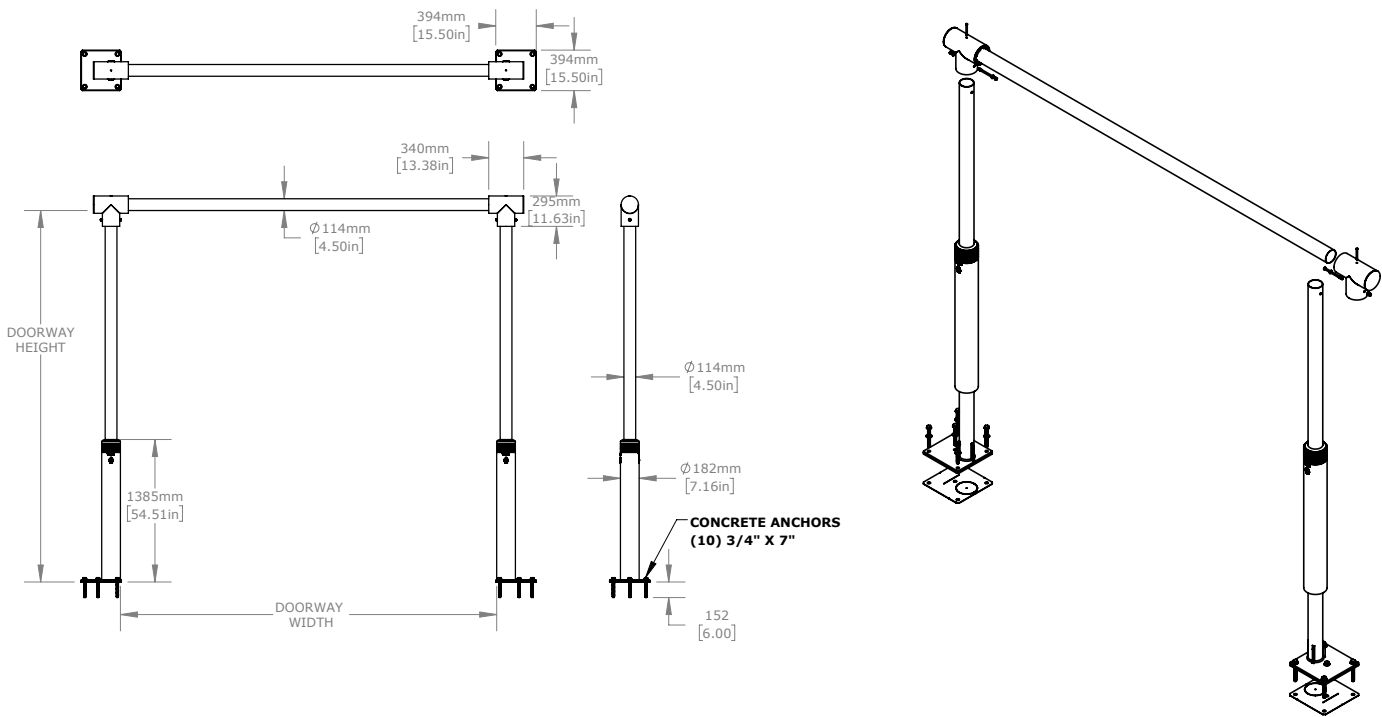

Materials: HDPE shells, steel tubing, steel coupler with EDPM shock absorbers, anchor kit

How to order: Goal Posts measurements are based on the opening dimensions. Goal post uprights and crossbars are available in standard opening dimensions of 8', 10', 12', 14', 16'



McCue Corporation
Peabody, MA 01960, USA
+1 (800) 800 8503
customer@McCue.com

McCue UK & Europe
Milton Keynes, United Kingdom
+44 (0)1908 365 511
uksales@mccue.com

McCue Asia
迈客(厦门)有限公司
Xiamen, Fujian, China
+86-592-2200790

mccue.com

