

# Hoops and Divider Rails

## Divider Rails

McCue's range of hoops and dividers are made from 304 grade stainless steel for very high strength, durability and weather-resistance. These products provide a high quality, low maintenance method of area segregation. There are potted and surface mounted versions available as well as special sizes – please call for more details.



- ! Robust, durable stainless steel with a visually aesthetic polished finish
- ! Low maintenance
- ! Suitable for a wide range of applications to protect both your sales area and help to guide your customers through your car park
- ! Available in 316, marine grade, please call for details

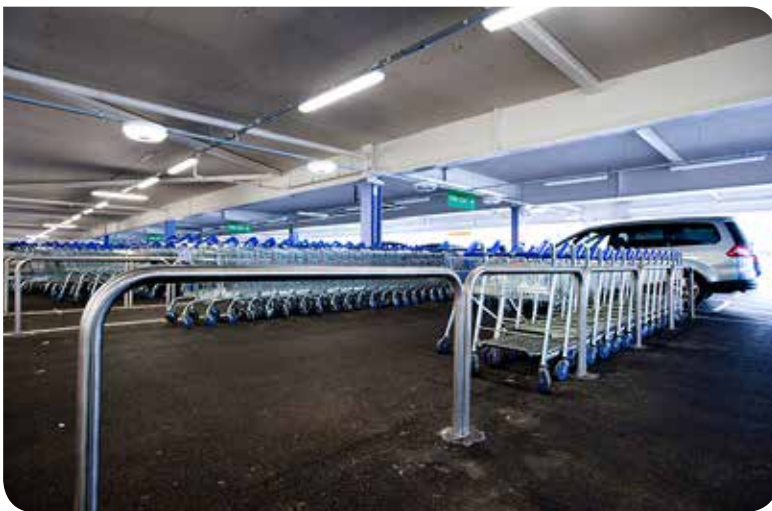

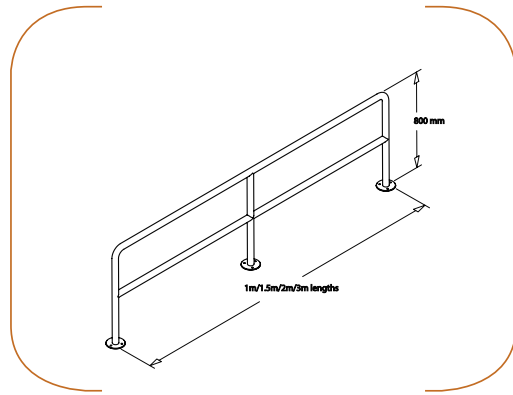
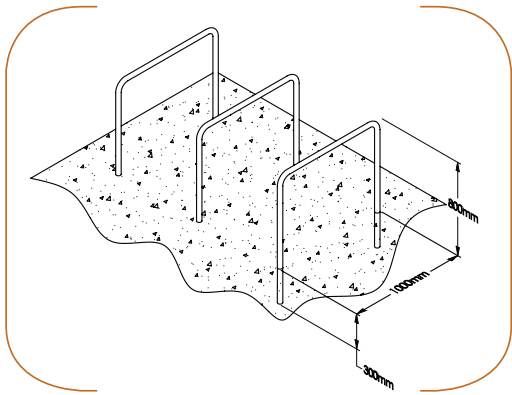

**McCue Cycle Hoop**

**SS-HOOP-CYCLE**

1000mm long x 1100mm high

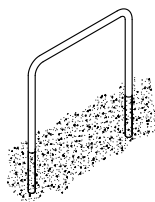

**Potted Trolley Hoop**

**SS-HOOP-LENGTH-HEIGHT**

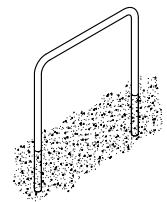

**Surface Mounted Trolley Hoop**

**SS-HOOP-LENGTH-HEIGHT SF**

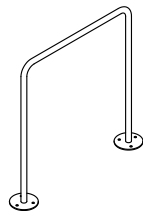

**Stainless Steel Divider Rail**

**SS-DR-LENGTH-HEIGHT-SF**

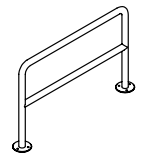

# Travelator Post

## Travelator Post

The McCue Travelator Post has been designed to funnel pedestrian traffic to prevent overcrowding around travelators and escalators. The high strength post has been engineered to meet the structural and installation requirements of BS EN 115-1:2008.

- ! Prevents dangerous overcrowding around travelators and escalators
- ! Inhibits trolleys and wheel equipment from being used on escalators and travelators
- ! Produced from high-quality stainless steel
- ! Highly-aesthetic brushed finish



### CartStop Travelator Post CSTP-B

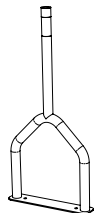

### M10 Screw and M16 Stud Kit FXG23-POST SET

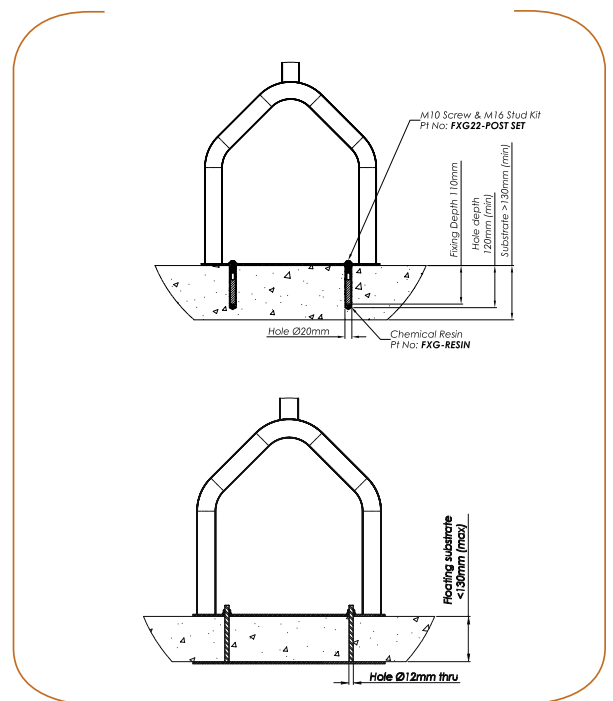

# I Beam Protection Kit

I Beam Protection Kit is specifically designed to protect columns in the sales floor and mezzanine environments. Manufactured from grade 304 stainless steel, the kit provides robust protection that is suitable for internal and external use. The modular kit has been designed to be cut and altered to fit any column size variations.

- ! Robust, durable stainless steel with a visually esthetic satin polished finish
- ! Nylon joining spigots for a seamless connection between tubes
- ! Modular to accommodate any column size variations
- ! Simple installation process



**I Beam Protection Kit**  
**SCM-446-447-KIT**

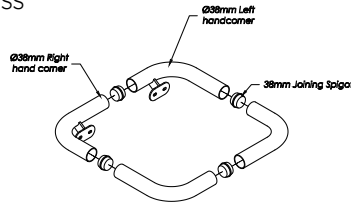

**End Caps**  
**MCCS-16**

(For half, quarter, 3 quarter installations).



# Circular Column Hoops

Circular Column Hoops are produced from grade 304 stainless steel for high strength and a long work life. In addition, the high-quality brushed finish compliments the overall appearance of the store-front. Available in a wide variety of diameters, the kit can protect circular columns from 90mm – 500mm diameter.

- ! Robust, durable stainless steel with a visually aesthetic brushed finish
- ! Suitable for internal and external use
- ! Simple installation process
- ! Available in 316 marine grade, please call for more details



**Half Column Hoop**  
**SCP-(COLUMN DIA)-38**

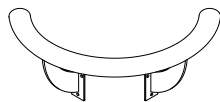

**Nylon End Cap**  
**MCCS-16**

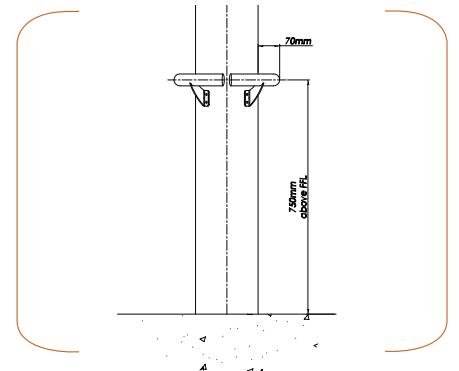

# Chrome Post

## Post Corner Protection

McCue's Chrome Post provides a visually aesthetic, heavy duty corner protection solution. The high strength post is simply installed using expansion bolts covered with a base plate for seamless and unobtrusive installation with the sales floor.

- ! Slimline, unobtrusive shape
- ! High strength and durability
- ! Quick and simple installation
- ! Visually aesthetic chrome finish



### Floor Mounted Chrome Post MCC-CHROME POST

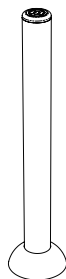

### M10 x 70mm Rawbolt FXG-MCCS-0

(3 bolts required per post)

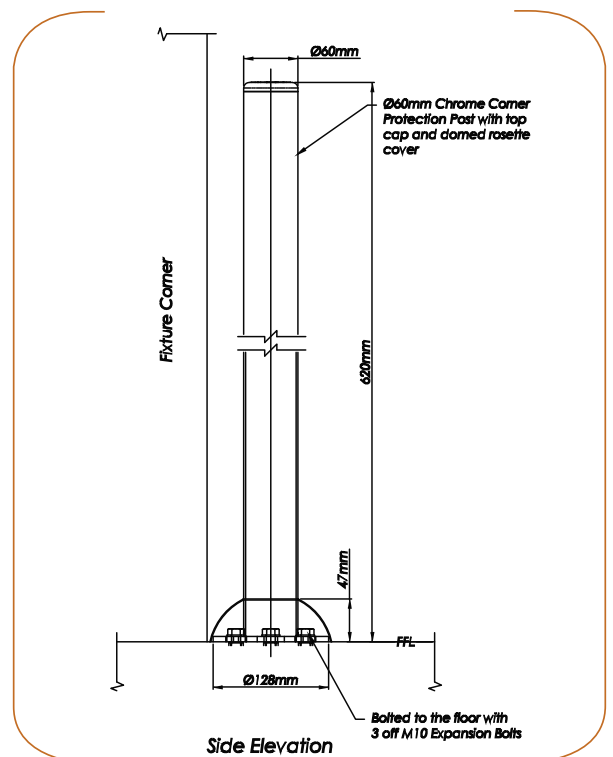

# Stainless Steel Post

## Post Corner Protection

McCue's Stainless Steel Post provides very high strength and visually aesthetic corner protection for valuable refrigeration units. The post stands at 610mm high and uses a cover to hide the floor fixings for seamless and unobtrusive seamless integration with the sales floor.

- ! Slimline, unobtrusive shape
- ! High strength and durability
- ! Quick and simple installation
- ! Visually aesthetic, polished finish

### Floor Mounted Stainless Steel Post MCC21

#### Post Cover MCCS-POST COVER

#### M10 x 70mm Rawbolt FXG-MCCS-0 (3 bolts required per post)

